

New in 2019

Great Basin™ Models
GB-1000 and GB-500

The Industry's First and Only
Performance Certified
500 and 1,000 Gallon
Grease Interceptors



SCHIER

CATALOG No.10

Introducing
Safety Star™ p. 28





SCHIER

Make it Better	05
Lifetime Guaranteed	07
Locally Stocked	09
Made in the USA	11
Pretreatment Pledge	13
Great Basin™ – Indoor Installations	14
Great Basin™ – Outdoor Installations	20
Covers	26
Safety Star™	28
Field Cut Risers	30
Pumpout Ports	32
Great Basin™ Performance	34
Grease Production Sizing™	36
Grease Monkey™ Sizing Tool	37
Maintenance	38
Great Basin™ Specifications	40
Big Foot™ Gravity Grease Interceptors	48
Sewer Viewer™ Sampling Port	50
Accessories	52



Kerry, one of Schier's Product Makers, secures an inlet connection for a model GB-250

MAKE IT BETTER

There's been a resurgence in the school of thought that things should be built to last. People now expect more from their coolers, jeans, workboots and blenders. We think you should expect the same from your grease interceptor. When we started with Schier in 2003, half of our products were made from steel. Guaranteed to fail. Some plumbers would half-joke "hey man, that's job security."

In 2006 when we launched the Great Basin™, we made a bet that our customers wanted something better. We believed that grease interceptors should not only be ridiculously efficient but they should also last a long time.

We think that job security comes not from built in obsolescence but rather by delivering value to your customers. Thank you for being a part of what we do. We look forward to working with you.



Charlie Ismert
President, Sales Director



Luke Ismert
CEO





LIFETIME GUARANTEED

Effective January 1st 2018 Schier Products represents and warrants that all grease interceptor products (“Products”) will be free from any and all defects in material and workmanship during the lifetime of the plumbing system in which the Products were originally installed and will, at its option, agree to repair, replace, or supply credit to the original purchaser.

This warranty does not cover wear and tear, extreme temperatures or pH levels, nor does it cover damage from naturally occurring phenomenon, including, but not limited to UV, freeze-related damage, or natural disasters. If the Products are warehoused without cover from the elements (direct sun, rain, sleet, snow, windblown gravel dust or sand) or are susceptible to damage from regular business traffic (passing forklifts and vehicles) this warranty will be null and void and the Products will not be considered for return. This warranty does not cover the purchaser’s cost for parts required in routine maintenance. This warranty shall be effective if, and only if, the Products were:

- a. installed in accordance with Schier Product’s notes, specifications and instructions, for installation, operation and maintenance;
- b. installed in conformance with all applicable building and plumbing codes and passed all applicable testing methods immediately following installation;
- c. not subjected to misuse or abuse, whether negligent or intentional;
- d. never modified, repaired or altered by any individual(s) not authorized by Schier Products;
- e. installed by a licensed plumber.

This warranty is the purchaser’s sole and exclusive remedy, and acceptance of this exclusive remedy is a condition of the purchase of these Products. In no event shall Schier Products be liable for any incidental, special, consequential or punitive damages, or for any costs, attorney fees, expenses, losses or delays claimed to be as a consequence of any damage to, failure of, or defect in any products including, but not limited to, any claims for loss of profits, transportation, removal and installation charges. This warranty is exclusive and in lieu of all other warranties or conditions, written or oral, expressed or implied.



8 Schier's '56 Chevy 6400 making a hometown delivery in Kansas City.



LOCALLY STOCKED

With over 300 brick and mortar dealers throughout North America, we have a nearby store with your Great Basin™ grease interceptor in-stock and ready for pick-up. Visit schierproducts.com to find your local dealer.

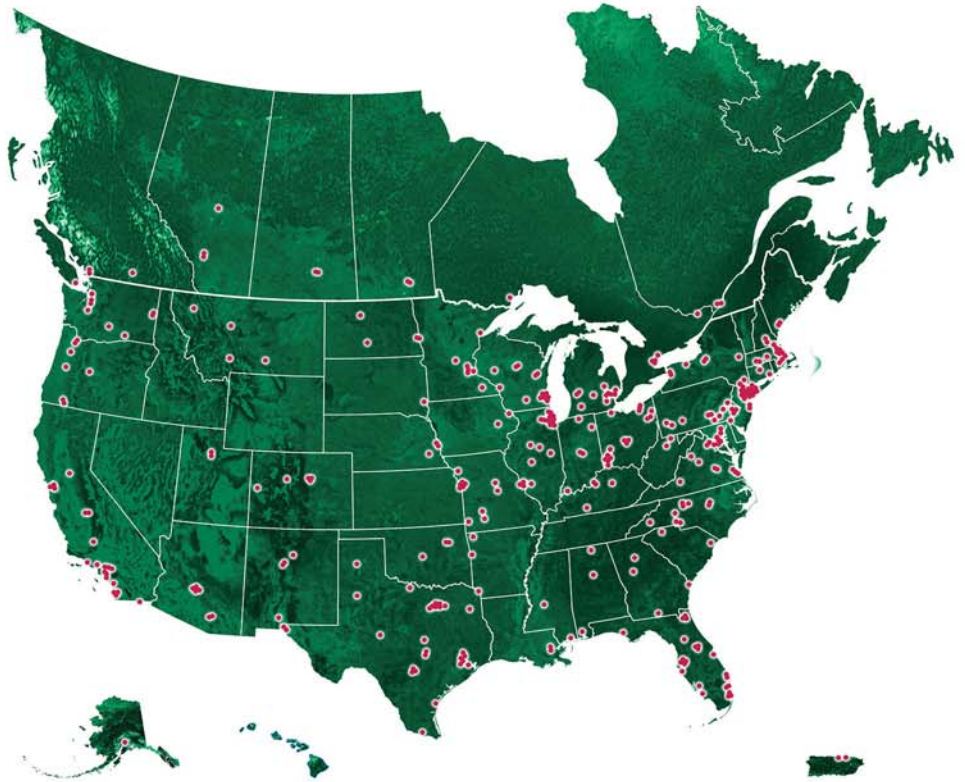



MADE
IN THE USA



Sergeant Michael Ismert, USA, assists with raising Schier's American flag on Veterans Day, 2017.

We're proud that all of our products are 100% American made. Making it here ensures better quality and reliable sourcing for every component. But we don't think you should buy from us just because we're Made in the USA; you should buy from us if you believe that we make the best product on the market. Simple as that.





PRETREATMENT PLEDGE

A healthy conveyance system requires a comprehensive approach that includes effective regulations and enforcement, kitchen best management practices and appropriately sized and maintained grease interceptors.

Schier is committed to forging a partnership with the pretreatment community to help reduce and eliminate the problems associated with grease in conveyance systems. To that end we pledge to:

- Design, test and manufacture products that provide the best separation efficiency, the most durable construction and the simplest installation, inspection and maintenance features
- Listen to your ideas regarding new and improved products
- Provide information and education on emerging technologies, industry studies and best practices from jurisdictions across the country

What we ask of you, our pretreatment officials, is to support an environment of innovation through collaboration with all stakeholders and openness to new and emerging technologies.

GREAT BASIN™

High Capacity Grease Interceptors



INDOOR INSTALLATIONS

Fully redesigned in 2017, Schier's lineup of indoor Great Basin™ models have reduced the complexity of product selection. Each model offers two flow rates, two pipe sizes and the ability to be installed under the sink or buried.

Small, medium, large. Simple.





GREAT BASIN™

High Capacity Grease Interceptors

Steel.

Good for bridges, bad for interceptors.



Replacing a failed steel interceptor at Chapel Hill

16 *Elementary School — Independence, Missouri.*



5 Years

typical steel lifespan

With the industry's only lifetime warranty, the Great Basin™ is perfect for replacing guaranteed-to-fail steel interceptors.

\$11,928 Lost*

Initial installation additional costs: **\$378**

5 years of extra pumpouts: **\$3,000**

Replacement cost after 5 years: **\$8,550**

* based on like Schier model alternative



Pizza Hut — Brookfield, Wisconsin.

GREAT BASIN™

High Capacity Grease Interceptors

OTO-
OTER®

LUMBERS



**Installs so fast your plumber
might leave his truck running.**

Three models ready for low profile or buried installations

With a new low profile design, more installations can go on the floor eliminating costly burials

Optional field cut riser

For buried installations up to 25"

Rugged cover design

Bolted and gasketed polypropylene cover with molded in tread pattern and large 20" diameter accessway

Built-in triple outlet

Saves time, space and piping

Open top diffuser

Open top outlet diffuser provides access for visual inspection

Optional 1/2" PVC extension handle

For easy flow control removal in deep burial installations

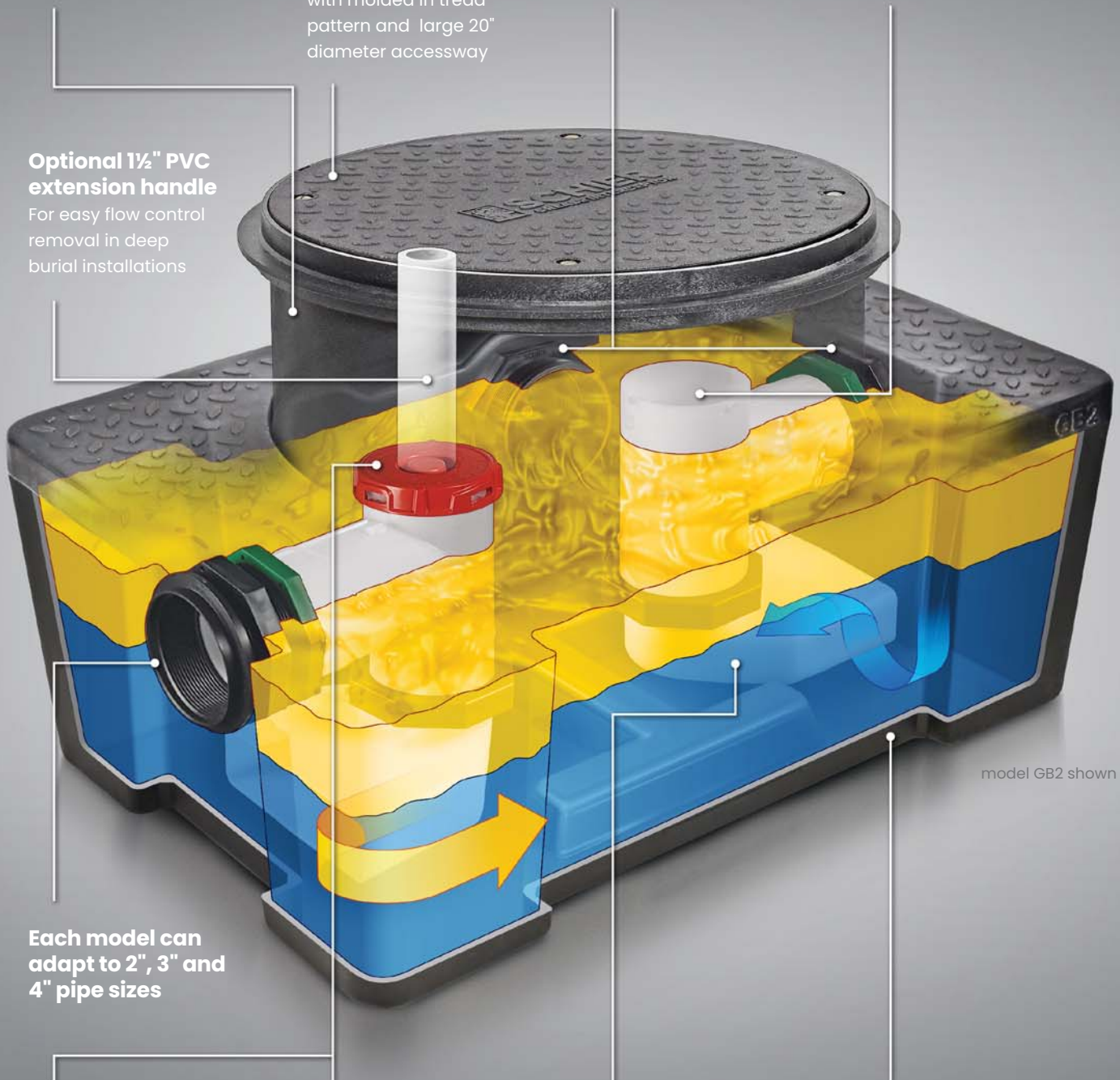

model GB2 shown

Each model can adapt to 2", 3" and 4" pipe sizes

Each model certified to dual flow rates

Flow Control Cartridge™

Saves up to 90 minutes of installation time versus units with external flow control – now removable from grade

Multi-directional diffuser feet

Maintains certified flow pattern regardless of diffuser orientation

Rugged body design

Up to 3/8" thick polyethylene body with structural support and molded-in lift handles

GREAT BASIN™

High Capacity Grease Interceptors



OUTDOOR INSTALLATIONS

Introduced in 2006, Schier's lineup of outdoor Great Basin™ models has reshaped the industry by offering a hybrid grease interceptor that is not only crazy efficient but rugged enough to be installed outside in a heavy traffic area.



GREAT BASIN™

High Capacity Grease Interceptors

Concrete.

Good for driveways, bad for interceptors.

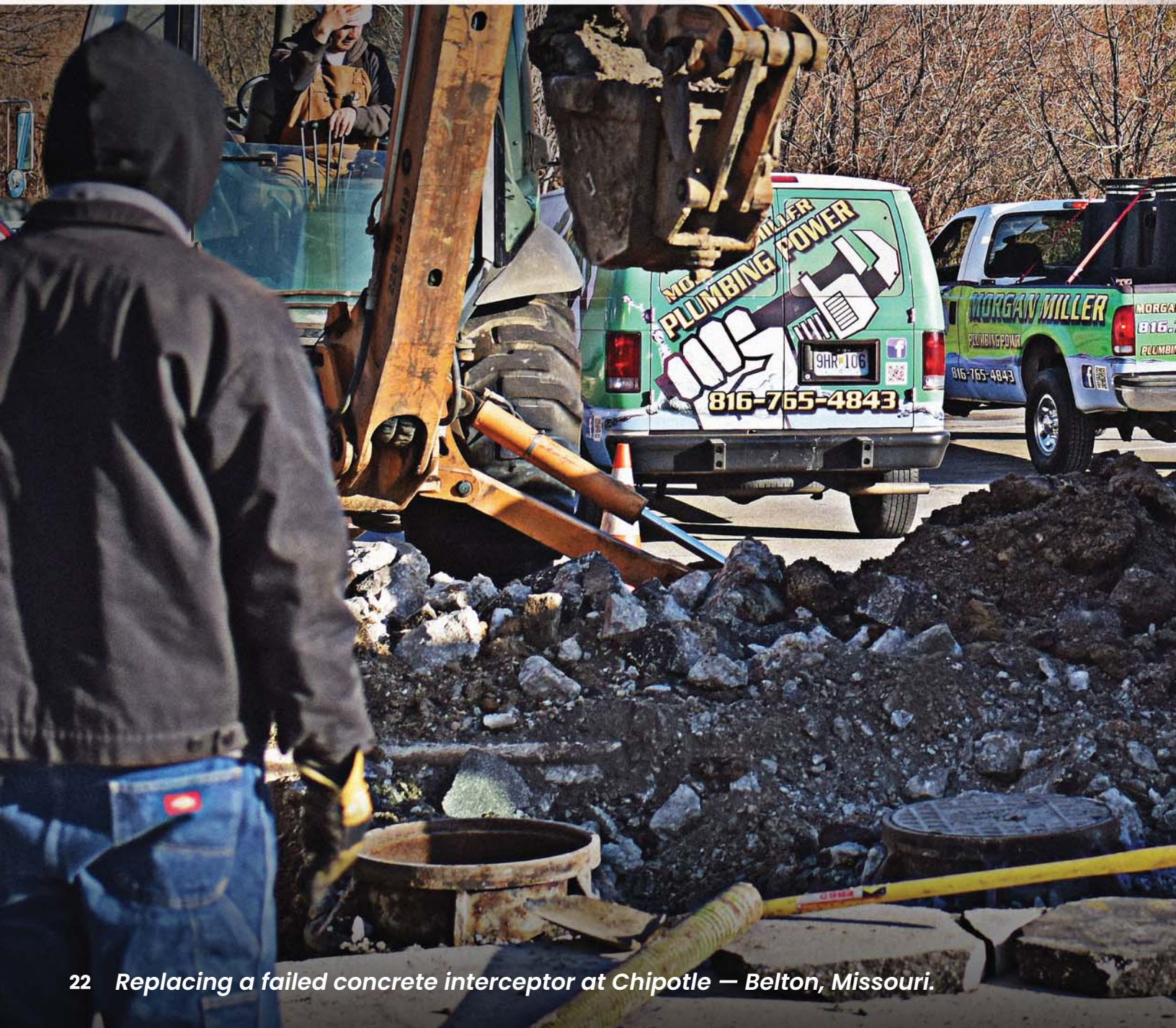



10 Years

typical concrete lifespan

With the industry's only lifetime warranty, the Great Basin™ is perfect for replacing guaranteed-to-fail concrete interceptors.

\$27,828

Lost*

Initial installation additional costs: **\$2,871**

10 years of extra pumpouts: **\$10,400**

Replacement cost after 10 years: **\$14,557**

* based on like Schier model alternative



McDonald's — Lee's Summit, Missouri

A photograph showing construction workers in safety gear installing a large, dark grey, rectangular grease interceptor into a deep trench. One worker in a blue hard hat and yellow vest is on the left, another in an orange vest and white hard hat is on the right, and a third in a green hard hat and yellow vest is in the foreground. The background shows a building with posters.

GREAT BASIN™

High Capacity Grease Interceptors

**Cancel the crane, and
be home by dinner.**

Optional field cut risers

Riser heights up to 94" for buried installations (cover adapters included)

Flow Control Cartridge™

For use in high flow scenarios – now removable from grade

Open top diffusers

Provide access for visual inspection – now standard in white for better visibility

Covers for every application

With molded in tread pattern, large 20" diameter accessway, and load ratings from pedestrian composite to H20 cast iron

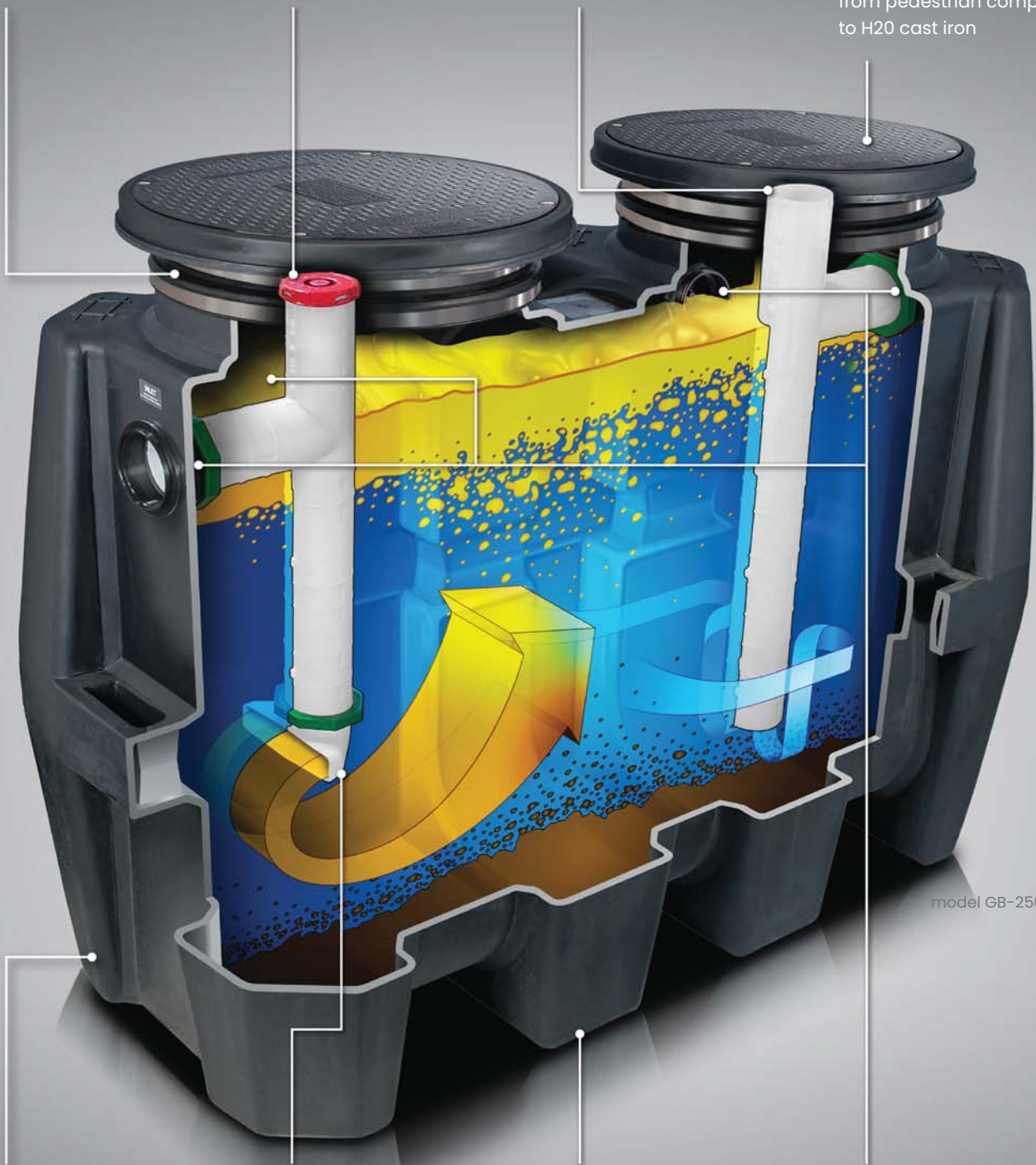

model GB-250 shown

Rugged body design

Up to 1/2" thick polyethylene body with molded-in lift handles exceeds ASTM C890 structural requirements for traffic installations

Multi-directional diffuser feet

Maintains certified flow pattern regardless of diffuser orientation

Fits through doorways

With a maximum width of 33-1/2" the GB-50, GB-75 and GB-250 fit through commercial doorways for interior installations

Built-in triple inlet/outlet*

Saves time, space and piping

* Not available with model GB-1000. Triple Inlet only available with models GB-250 and GB-500.

GREAT BASIN™

High Capacity Grease Interceptors

We've got you covered.





COVERS

Covers are provided with water/air tight gasket seal and are designed to fit tightly into a key-fit frame.



C21M

Location: indoor
Diameter: 21" (53.3 cm)
Type: bolted polypropylene
Pedestrian Load Rating: 1,000 lbs. (454 kg)
Models: GB1, GB2, GB3



C24H

Location: outdoor/indoor
Diameter: 24" (61.0 cm)
Type: bolted composite
Traffic Load Rating: 16,000 lbs. (7,257 kg)
Models: GB-50, GB-75, GB-250, SV24



C24H2

Location: outdoor/indoor
Diameter: 24" (61.0 cm)
Type: bolted composite
Traffic Load Rating: 16,000 lbs. (7,257 kg)
Models: GB-500, GB-1000, GGI-750, GGI-1500



C24HP

Location: outdoor
Diameter: 24" (61.0 cm)
Type: pickable cast iron
H2O Load Rating: 16,000 lbs. (7,257 kg)
Models: GB-50, GB-75, GB-250, GB-500, GB-1000, GGI-750, GGI-1500, SV24

BUILT LIKE A TANK



Models GB-75, GB-250, GB-500, GB-1000, GGI-750 and GGI-1500 exceed structural loading design requirements of ASTM C890 for A-16 vehicle loading (AASHTO HS20).

GREAT BASIN™

High Capacity Grease Interceptors

**The feature nobody asked for,
but everyone needs.**



SAFETY STAR™

Every year fatalities happen due to open sewer manholes including drowning, entrapment and inhaling poisonous (H₂S) gas. Schier's Safety Star™ provides enough access for routine maintenance like pumping and inspection, while keeping the man-way closed to accidental entry. Look for the Safety Star™ to be incorporated into the entire Schier lineup in the near future.

- Load-rated at 450 lbs
- Allows access for pump-out and inspection while in place
- Can be partially removed for full access to man-way (confined space entry)
- Safety Star is tethered to the cover adapter with a proprietary 24" long UV and rot-resistant polypropylene strap.
- For optional security enhancement, a pre-molded pilot hole is provided for a tamper-resistant screw



Partially removable for full access during maintenance

GREAT BASIN™

High Capacity Grease Interceptors

Depth perfection.



FIELD CUT RISERS

Eliminate jobsite downtime and custom riser costs with a simple, off-the-shelf and field modifiable design.



FCRI



Models: GB1, GB2, GB3

Height Needed	Risers Required
2 1/8" – 12"	FCRI
>12" – 25"	FCRI (x2)



Models: GB-50, GB-75, GB-250, SV24

Height Needed	Risers Required*
0 – 3 1/2"	included via cover adapter
5" – 23"	SR24
>23" – 38"	LR24
>38" – 43"	SR24 (x2)
>43" – 58"	SR24 + LR24
>58" – 72"	LR24 (x2)

* per accessway; GB-50 max riser height is 38"



Models: GB-500, GB-1000, GGI-750, GGI-1500 (require 2 per tank)

Height Needed	Risers Required (per accessway)
0 – 4"	included via cover adapter
4" – 34"	FCR2
>34" – 64"	FCR2 (x2)
>64" – 94"	FCR2 (x3)



GREAT BASIN™

High Capacity Grease Interceptors

Don't get hosed.

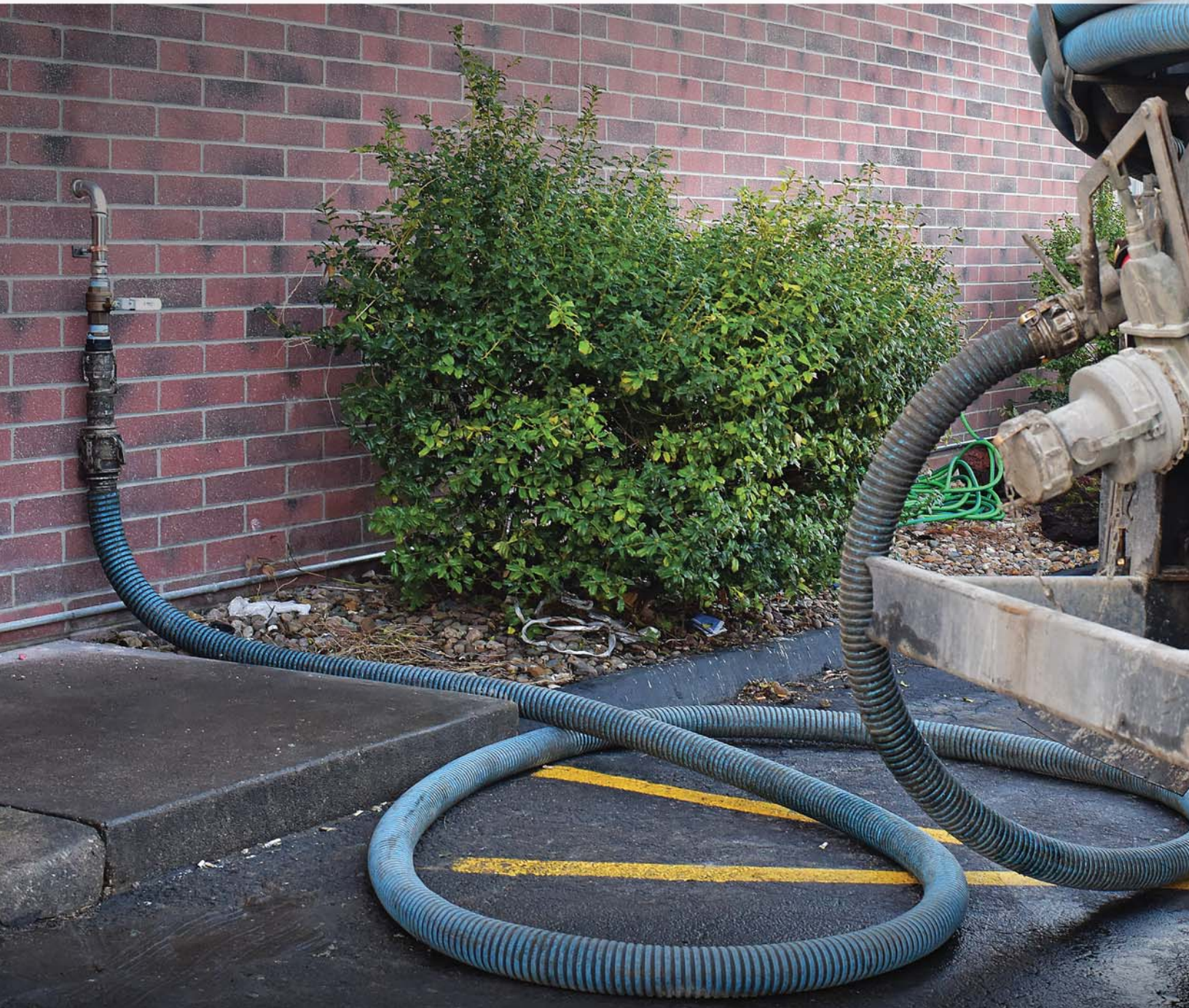



PUMPOUT PORTS

Make disease-ridden hoses and putrid smells inside your kitchen a thing of the past. Outfit your indoor Great Basin™ with a pumpout port for remote cleaning during normal business hours.

Model	Pumpout Port
GB1 GB2 GB3	PP1
GB-50 GB-75 GB-250	PP2
GB-500	PP3



Proprietary low profile elbow connects to any of the unused outlets (model PP1 shown on GB2).



Typical pumper hose on kitchen floor during pumpout.

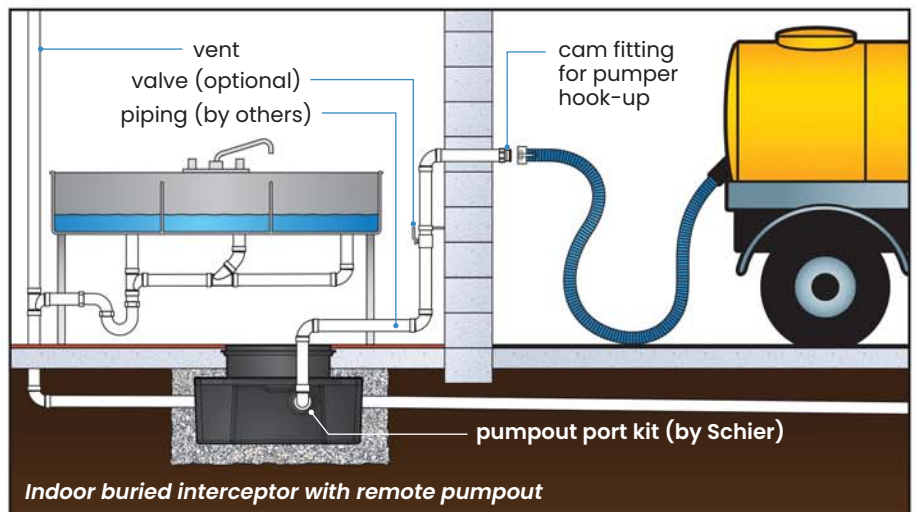

Indoor buried interceptor with remote pumpout

GREAT BASIN™

High Capacity Grease Interceptors

Big grease. Small footprint.

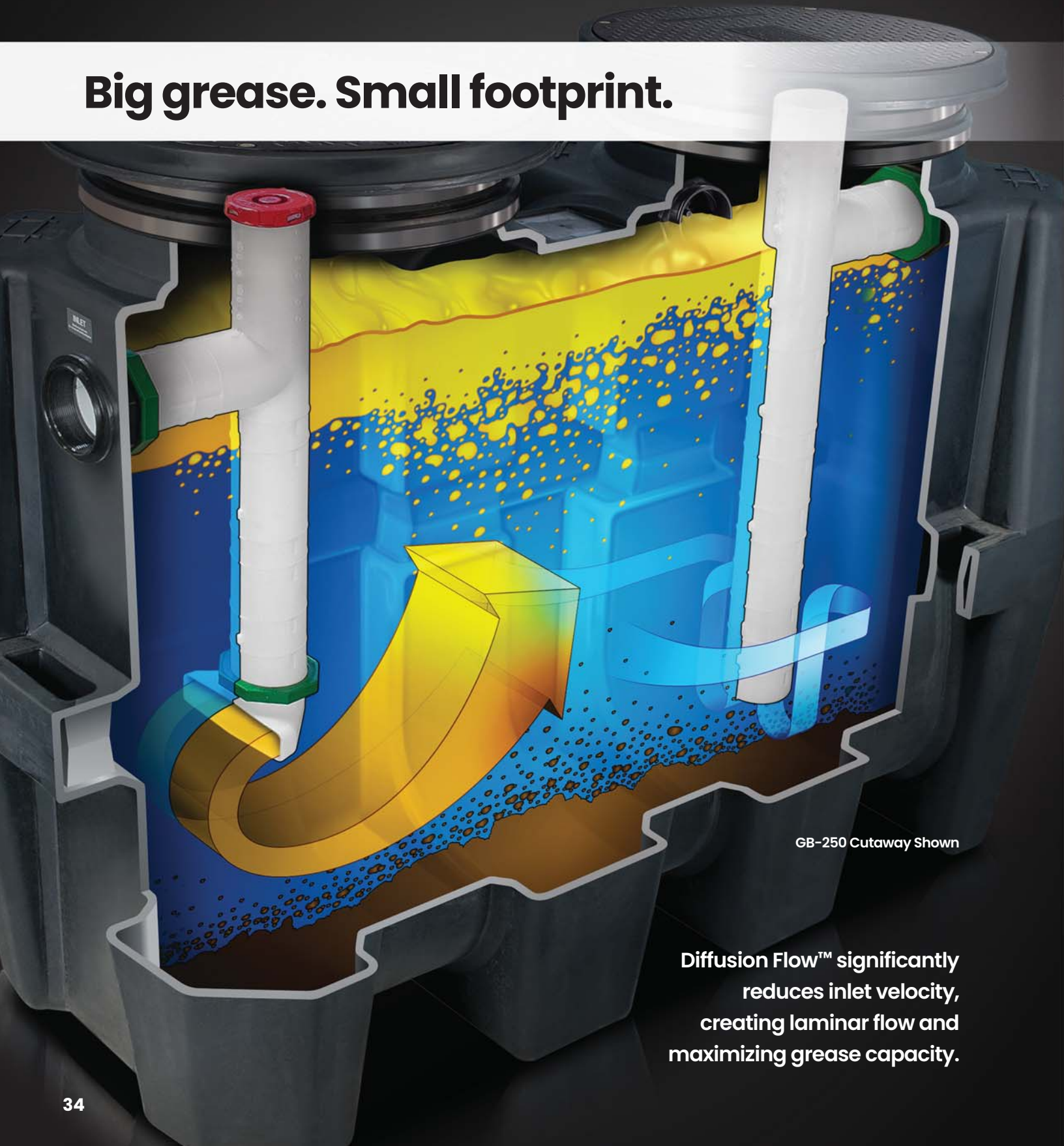

GB-250 Cutaway Shown

Diffusion Flow™ significantly reduces inlet velocity, creating laminar flow and maximizing grease capacity.

Schier Engineering Technician dewatering effluent during performance testing.

Summary of Great Basin™ Performance

For complete versions of Great Basin™ ASME/CSA lab tests, visit schierproducts.com

model	flow rate - GPM (L/s)	total liquid volume - gal. (L)	min. grease requirement - lbs. (kg)	grease retained - lbs. (kg)	total liquid height - in. (mm)	total grease height - in. (mm)
GB1	20 (1.3)	10 (37.9)	40 (18.1)	70 (31.8)	5.25 (133)	5 (127)
	25 (1.6)	10 (37.9)	50 (22.7)	64 (29.0)	5.25 (133)	4.6 (117)
GB2	35 (2.2)	20 (75.7)	70 (31.8)	130 (59.0)	7 (178)	6.25 (159)
	50 (3.2)	20 (75.7)	100 (45.4)	127 (57.6)	7 (178)	6.1 (155)
GB3	50 (3.2)	40 (151.4)	100 (45.4)	272 (123.4)	13.75 (349)	12.8 (325)
	75 (4.7)	40 (151.4)	150 (68.0)	175 (79.4)	13.75 (349)	8.25 (210)
GB-50	50 (3.2)	52 (196.5)	100 (45.4)	249 (112.9)	16 (406)	9.1 (231)
GB-75	75 (4.7)	125 (473.2)	150 (68.0)	653 (296.2)	24 (610)	16.6 (422)
GB-250	100 (6.3)	275 (1,041.0)	200 (90.7)	1,751 (794.2)	36 (914)	30 (762)
	200 (12.6)	275 (1,041.0)	400 (181.4)	1,196 (542.5)	36 (914)	20 (508)
GB-500	100 (6.3)	510 (1,930.6)	200 (90.7)	3,048 (1,382.6)	35 (889)	25.8 (655)
GB-1000	100 (6.3)	1,010 (3,823.3)	200 (90.7)	6,547 (2,969.7)	54 (1,372)	42.0 (1,067)

All models listed by IAPMO to ASME A112.14.3 and CSA B481.1. See Schier listing at pld.iapmo.org/file_info.asp?file_no=0005317

ASME A112.14.3/CSA B481.1 Test Procedure

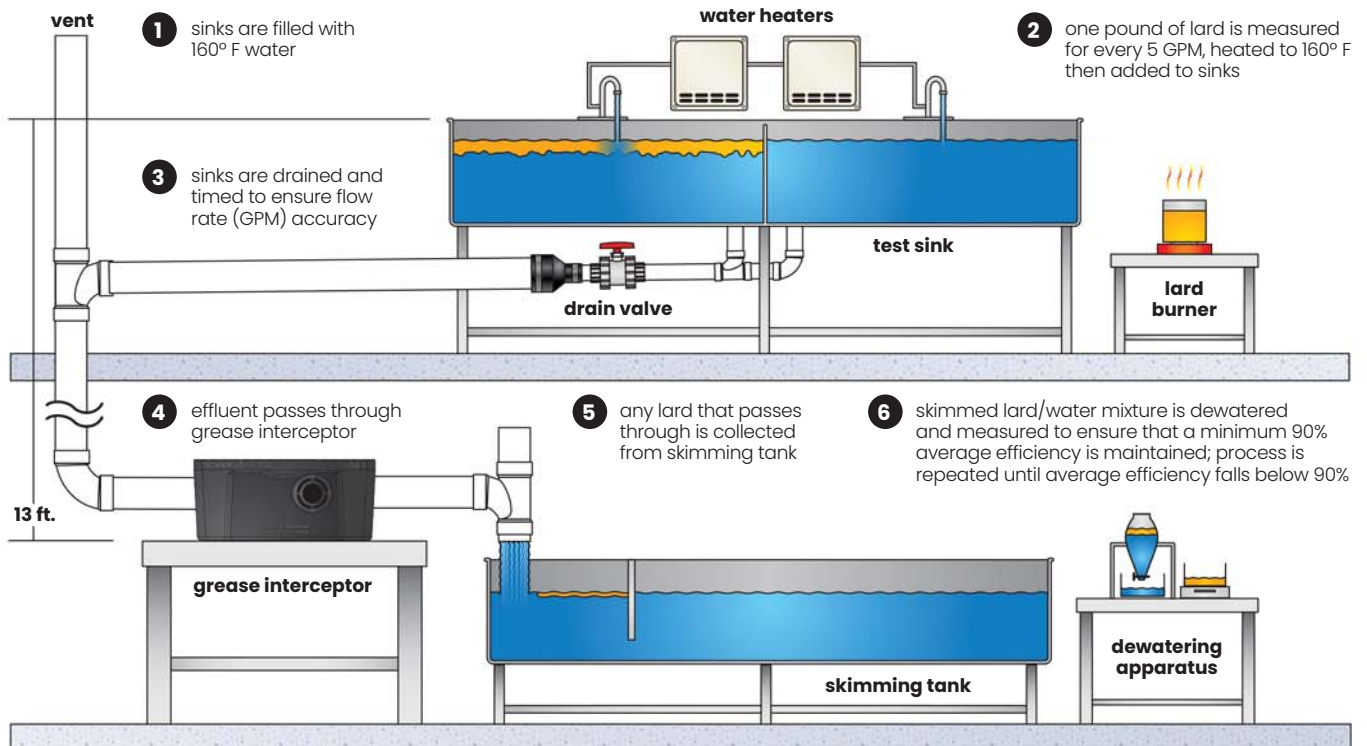



GREASE PRODUCTION SIZING™

First introduced by Schier in 2012, Grease Production Sizing™ (GPS) has been used to size over 50,000 restaurant grease interceptors, has been adopted by several municipalities, published in the 2016 edition of ASPE's *Plumbing Engineering Design Handbook* and now powers our Grease Monkey™ sizing tool (see following page).

Step 1: Size by Flow Rate

hydromechanical grease interceptor sizing using gravity flow rates (per Ch. 10 of the Uniform Plumbing Code)

diameter of grease waste pipe	maximum full pipe flow*	size of grease interceptor	
		one-minute drainage period	two-minute drainage period
2"	20 GPM	20 GPM	10 GPM
3"	60 GPM	75 GPM	35 GPM
4"	125 GPM	150 GPM	75 GPM
6"	375 GPM	400 GPM	200 GPM

*¼ inch slope per foot based on Manning's formula with friction factor N = 0.012.

 Recommended

Step 2: Select Grease Capacity for Pumpout Frequency

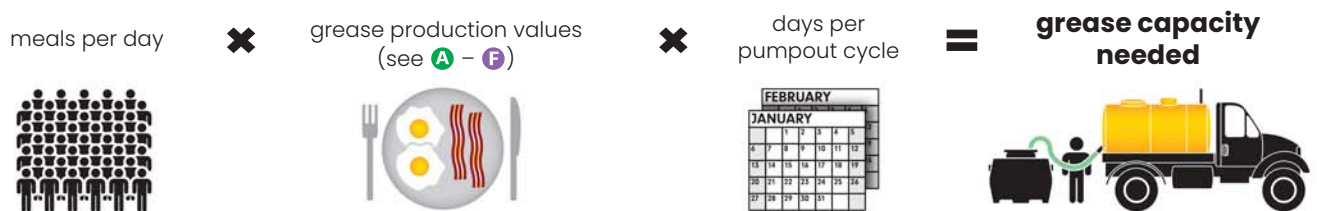

Foodservice Establishment (FSE) Grease Production Values

category	grease production values	description / examples
low	A 0.005 lbs / meal (no flatware)	serves food prepared offsite or food that requires minimal preparation and/or warming; bar (drinks only), coffee shop, continental breakfast, convenience store, deli, donut shop (w/o fryer), ice cream / yogurt / smoothies, pizza carryout, sandwich shop, sushi, snack bar
	B 0.0065 lbs / meal (with flatware)	
medium	C 0.025 lbs / meal (no flatware)	serves foods from a limited menu and/or with a limited amount of onsite preparation; cafeteria (heat and serve), caterer, fast food (pre-cook), pizza restaurant, salad/healthy bowls, low category restaurants w/ fryer
	D 0.0325 lbs / meal (with flatware)	
high	E 0.035 lbs / meal (no flatware)	serves a full menu of food prepared onsite; bakery, bar and grille, BBQ, buffet, cafeteria (full serve), Chinese, donut shop (w/fryer), family restaurant, fast food (full prep), fried chicken, Greek, grocery store, Indian, Italian, seafood, steak house, medium category restaurants w/ fryer
	F 0.0455 lbs / meal (with flatware)	

Please note that GPS may not satisfy local jurisdictional requirements for installation approval and should always be verified prior to selection. The easiest way to verify sizing for any project is to use our Grease Monkey™ sizing tool and select the "pre-approve" option.

Schier Sizing Experts Nick and Tye assisting plumbing engineer with local project.

GREASE MONKEY™

Grease Interceptor Sizing Service

There's just no shortcut to correctly size a grease interceptor...
until now.

The new Grease Monkey™ sizing tool guides you quickly through all aspects of sizing, produces printable and shareable sizing calculations and comes with our complimentary pre-approval service in which we double-check your work and confirm local code approval for your grease interceptor installation.

schierproducts.com/pages/sizing



MAINTENANCE

Routine Maintenance Procedure

1. Remove cover(s).
2. Remove all contents of the grease interceptor including grease, sediment and wastewater. For most thorough cleaning contact a professional pumper contractor.
3. Run sinks to fill unit(s) with cold water.
4. Inspect cover gasket for wear and tear. Replace cover(s)
5. Dispose of grease per local code.

Routine Maintenance Clearance Heights:

model(s)	GB1, GB2, GB3	GB-50	GB-75, GB-250, GB-500	GB-1000
minimum clearance height (inches)	5.5	12	16	72

Grease Interceptor Anatomy (Model GB-500 Shown)

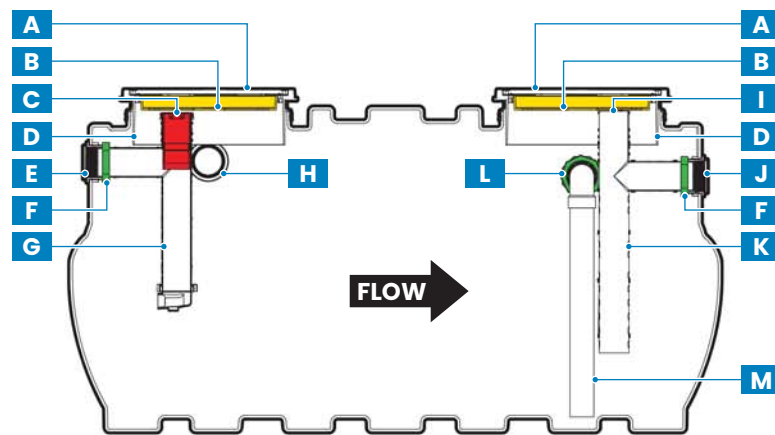

- A** Cover
- B** Safety Star™
- C** Flow Control Cartridge™
- D** Cover Adapter
- E** Inlet Connection
- F** Diffuser Retaining Nut
- G** Inlet Diffuser
- H** Optional Inlet Connection
- I** Air Relief/Visual Access
- J** Outlet Connection
- K** Outlet Diffuser
- L** Optional Outlet Connection
- M** Optional Pumpout Port



Core Samples

If you prefer not to rely solely on the GPSM to dictate pre-scheduled monthly pump-outs, you can take a more commanding role in dictating pump-out frequency with some simple tools and regular inspections. To do this you will need a core sampler. Popular brand names include DipStick Pro and Sludge Judge .

Once you have your core sampler, it can be outfitted with some simple labeling (via high adhesive tape or permanent marker) to indicate your pump-out levels (see below).

NOTE: Series Installations



When installed in series, initially the first unit will fill up with grease while passing some grease to subsequent unit(s). As the grease layer in the first unit grows, more grease will pass to subsequent units. When it reaches maximum capacity, the first unit will pass all grease to subsequent unit(s). Core samples should be taken from the final tank in the series and pumpout scheduling should be conducted when it is near full capacity.

GB-250 (100 GPM) Core Sample at Full Capacity

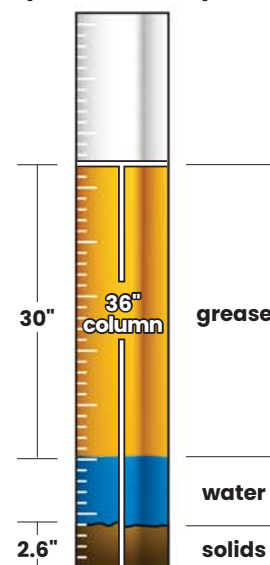

Core Sample Measurements at Full Capacity*

model	flow rate (GPM)	total liquid height (inches)	maximum grease height (inches)	maximum grease % of volume	maximum solids height (inches)
GB1	20	5.25	5	95%	0.75
	25	5.25	4.6	88%	0.75
GB2	35	7	6.25	89%	0.75
	50	7	6.1	87%	0.75
GB3	50	13.75	12.8	93%	0.75
	75	13.75	8.25	60%	0.75
GB-50	50	16	9.1	66%	3.3
GB-75	75	24	17.3	71%	1.5
GB-250	100	36	30	87%	2.6
	200	36	20	59%	2.6
GB-500	100	35	25.8	82%	10.9
GB-1000	100	54	42	89%	4.8
	200	54	29	55%	4.8

* Please note that as the grease layer inside of a grease interceptor accumulates it displaces the water below it downward. Much like an iceberg this grease layer will partially float above the static water line while the majority of it rests below it. As a result, the static water line of grease interceptor when at total grease capacity is slightly greater than the standard published static water line.

GB1

20/25 GPM Indoor Grease Interceptor

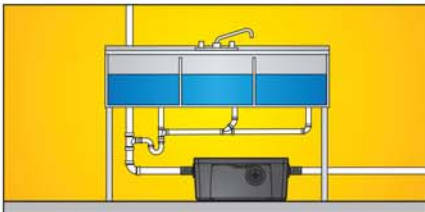

Under-Sink

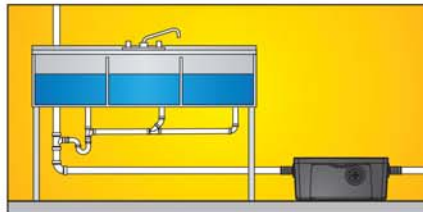

Next-to-Sink

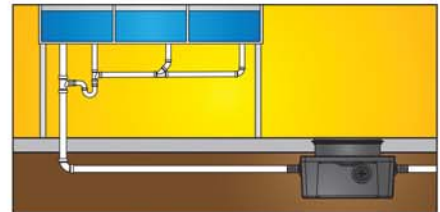

Buried

Standard

Location: Indoor

Installation: Above/Below Grade, Low-Profile

Flow Rates / Grease Capacities:

20 GPM (1.3 L/s) / 70 lbs. (32 kg)

25 GPM (1.6 L/s) / 64.9 lbs. (29 kg)

Solids Capacity: 1.3 gal. (4.9 L)

Liquid Capacity: 10 gal. (38 L)

Weight: 39 lbs. (18 kg)

Connections: 2" (50 mm) and 3" (75 mm) Plain End

Cover: Bolted Gas/Water Tight Polypropylene with 1,000 lb. Load Rating when Unit Is Buried with FCRI Riser



Listed by IAPMO to ASME A112.14.3 and CSA B481.1.

Accessories

FCRI: Field Cut Riser

CCI: Membrane Clamping Collar Kit (requires FCRI riser)

PPI: Pumpout Port Kit

PLAIN-EA-44: 4" (100 mm) Plain End Fitting

FPT-EA-34: 4" x 3" (100 x 75 mm) FPT Fitting

FPT-EA-23: 3" x 2" (75 x 50 mm) FPT Fitting

Also available in 15 GPM configuration. See GB1-CT online for more details.

GB2

35/50 GPM Indoor Grease Interceptor

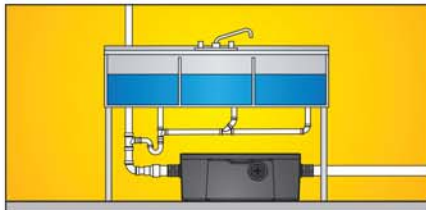

Under-Sink

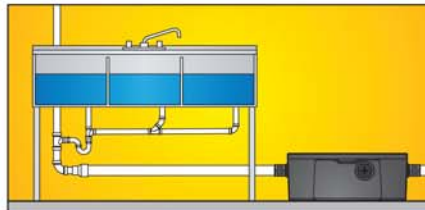

Next-to-Sink

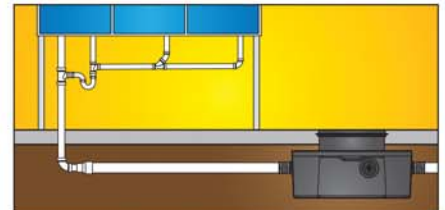

Buried

Standard

Location: Indoor

Installation: Above/Below Grade, Low-Profile

Flow Rates / Grease Capacities:

35 GPM (2.2 L/s) / 130.5 lbs. (59 kg)

50 GPM (3.2 L/s) / 127.6 lbs. (58 kg)

Solids Capacity: 1.8 gal. (6.8 L)

Liquid Capacity: 20 gal. (76 L)

Weight: 49 lbs. (22 kg)

Connections: 3" (75 mm) and 4" (100 mm) Plain End

Cover: Bolted Gas/Water Tight Polypropylene with 1,000 lb. Load Rating when Unit Is Buried with FCRI Riser



Listed by IAPMO to ASME A112.14.3 and CSA B481.1.

Accessories

FCRI: Field Cut Riser

PPI: Pumpout Port Kit

CCI: Membrane Clamping Collar Kit (requires FCRI riser)

SGK2: Support Gusset Kit

PLAIN-EA-24: 2" (50 mm) Plain End Fitting

FPT-EA-34: 4" x 3" (100 x 75 mm) FPT Fitting

FPT-EA-23: 3" x 2" (75 x 50 mm) FPT Fitting

Also available in 25 GPM configuration. See GB2-CT online for more details.

GB3

50/75 GPM Indoor Grease Interceptor

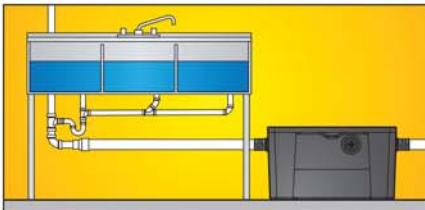

Next-to-Sink

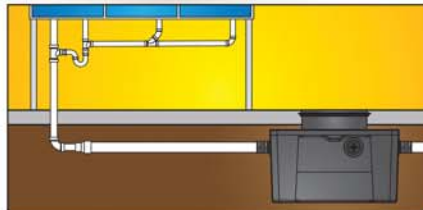

Buried

Standard

Location: Indoor

Installation: Above/Below Grade, Low-Profile

Flow Rates / Grease Capacities:

50 GPM (3.2 L/s) / 272.7 lbs. (124 kg)

75 GPM (4.7 L/s) / 175.6 lbs. (80 kg)

Solids Capacity: 1.9 gal. (7.2 L)

Liquid Capacity: 40 gal. (151 L)

Weight: 69 lbs. (31 kg)

Connections: 3" (75 mm) and 4" (100 mm) plain end

Cover: Bolted Gas/Water Tight Polypropylene with 1,000 lb. Load Rating when Unit Is Buried with FCRI Riser



Listed by IAPMO to ASME A112.14.3 and CSA B481.1.

Accessories

FCRI: Field Cut Riser

PPI: Pumpout Port Kit

CC1: Membrane Clamping Collar Kit (requires FCRI riser)

SGK3: Support Gusset Kit

PLAIN-EA-24: 2" (50 mm) Plain End Fitting

FPT-EA-34: 4" x 3" (100 x 75 mm) FPT Fitting

FPT-EA-23: 3" x 2" (75 x 50 mm) FPT Fitting

Also available in 50 GPM (only) configuration. See GB3-CT online for more details.

GB-50

50 GPM Indoor/Outdoor Grease Interceptor

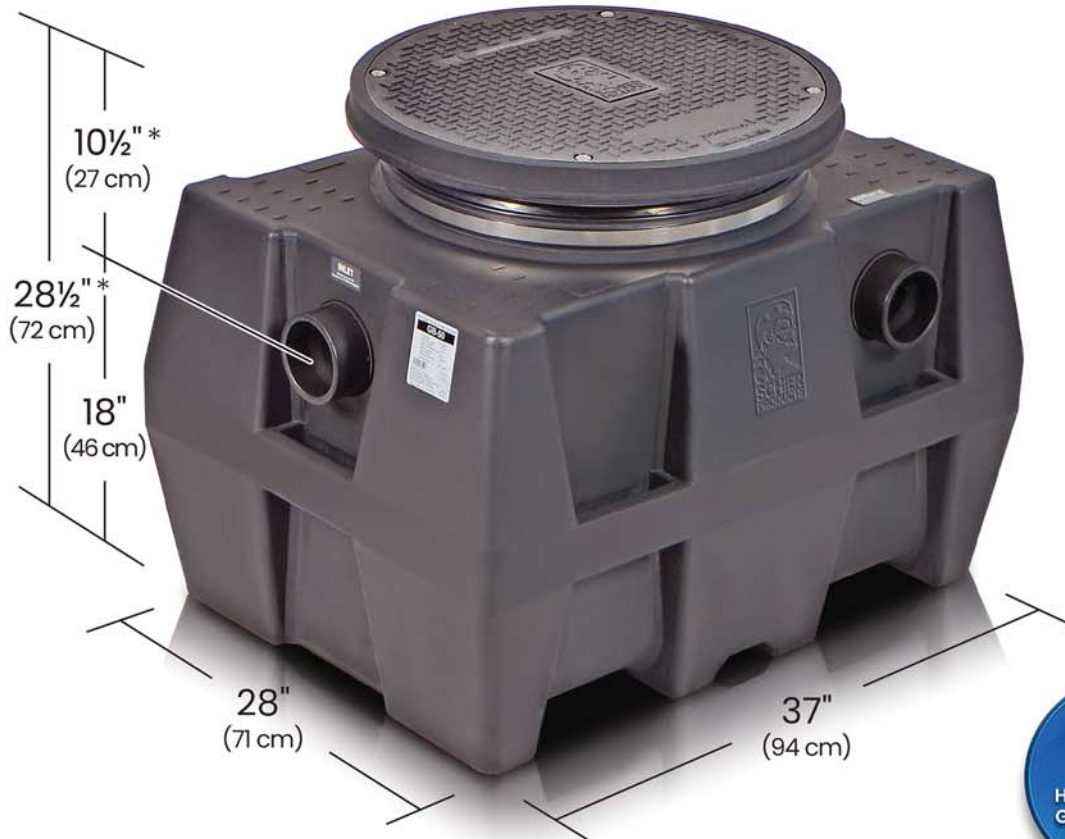

Standard

Location: Indoor/Outdoor

Installation: Above/Below Grade

Flow Rate / Grease Capacity:

50 GPM (3.2 L/s) / 249 lbs. (113 kg)

Solids Capacity: 12.5 gal. (45 L)

Liquid Capacity: 52 gal. (197 L)

Weight: 92 lbs. (42 kg)

Connections: 4" (100 mm) Plain End

Cover: Bolted Gas/Water Tight Composite with 16,000 lb. Load Rating



Listed by IAPMO to ASME A112.14.3 and CSA B481.1.

Options

C24HP: H20 Rated Pickable Cast Iron Cover

4" (100 mm) MPT

3" (75 mm) Plain End

3" (75 mm) MPT

Accessories

AKI: High Water Anchor Kit

SR24: Short Riser

LR24: Long Riser

CC2: Membrane Clamping Collar Kit

PP2: Pumpout Port Kit

* Add up to 3½" when adapter is elevated

† Certified to greatly exceed minimum grease storage capacity requirements

GB-75

75 GPM Indoor/Outdoor Grease Interceptor



Standard

Location: Indoor/Outdoor

Installation: Above/Below Grade

Flow Rate / Grease Capacity:

75 GPM (4.7 L/s) / 653 lbs. (296 kg)

Solids Capacity: 19.2 gal. (73 L)

Liquid Capacity: 125 gal. (473 L)

Weight: 130 lbs. (59 kg)

Connections: 4" (100 mm) Plain End

Cover: Bolted Gas/Water Tight Composite with 16,000 lb. Load Rating



Listed by IAPMO to ASME A112.14.3 and CSA B481.1.

Options

C24HP: H2O Rated Pickable Cast Iron Cover

4" (100 mm) MPT

6" (150 mm) Plain End

6" (150 mm) MPT (Stainless Steel)

Accessories

AK1: High Water Anchor Kit

SR24: Short Riser

LR24: Long Riser

CC2: Membrane Clamping Collar Kit

PP2: Pumpout Port Kit

* Add up to 3½" when adapter is elevated

† Certified to greatly exceed minimum grease storage capacity requirements

GB-250

100/200 GPM Indoor/Outdoor Grease Interceptor

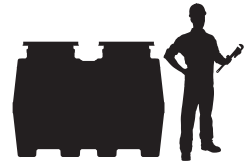

Standard

Location: Indoor/Outdoor

Installation: Above/Below Grade

Flow Rate / Grease Capacity:

100 GPM (6.3 L/s) / 1,751 lbs. (794 kg)

200 GPM (12.6 L/s) / 1,196 lbs. (543 kg)

Solids Capacity: 21 gal. (80 L)

Liquid Capacity: 275 gal. (1,040 L)

Weight: 230 lbs. (104 kg)

Connections: 4" (100 mm) Plain End

Cover: Bolted Gas/Water Tight Composite with 16,000 lb. Load Rating



Listed by IAPMO to ASME A112.14.3 and CSA B481.1.

Options

C24HP: H20 Rated Pickable Cast Iron Cover

4" (100 mm) MPT

6" (150 mm) plain end

6" (150 mm) MPT (stainless steel)

Accessories

AK1: High Water Anchor Kit

SR24: Short Riser

LR24: Long Riser

CC2: Membrane Clamping Collar Kit

PP2: Pumpout Port Kit

* Add up to 3 1/2" when adapter is elevated

† Certified to greatly exceed minimum grease storage capacity requirements

GB-500

100 GPM Indoor/Outdoor Grease Interceptor



Includes Safety Star™

Standard

Location: Indoor/Outdoor

Installation: Above/Below Grade

Flow Rate / Grease Capacity:

100 GPM (6.3 L/s) / 3,048 lbs. (1,382 kg)

Solids Capacity: 128 gal. (485 L)

Liquid Capacity: 510 gal. (1,931 L)

Weight: 528 lbs. (239 kg)

Connections: 4" (100 mm) plain end

Cover: Pickable Gas/Water Tight Cast Iron with H20 Load Rating



Listed by IAPMO to ASME A112.14.3 and CSA B481.1.

Listed by IAPMO to ANSI Z1001, spring 2019.

Options

C24H2: Highway Rated Bolted Composite Cover

6" (150 mm) Plain End

6" (150 mm) MPT (stainless steel)

Accessories

AK2: Anchor Kit

AGS2: Above Grade Support Kit

PP3: Pumpout Port Kit

FCR2: Riser to Grade

CC2: Membrane Clamping Collar Kit

* Add up to 4" when adapter is elevated

GB-1000

100 GPM Indoor/Outdoor Grease Interceptor



**Includes
Safety Star™**



Standard

Location: Indoor/Outdoor

Installation: Below Grade Only

Flow Rate / Grease Capacity:

100 GPM (6.3 L/s) / 6,547 lbs. (2,970 kg)

Solids Capacity: 103 gal. (390 L)

Liquid Capacity: 1,010 gal. (3,823 L)

Weight: 1,400 lbs. (635 kg)

Connections: 6" (150 mm) Plain End

Cover: Pickable Gas/Water Tight Cast Iron with H20 Load Rating



Listed by IAPMO to ASME A112.14.3 and CSA B481.1.

Options

C24H2: Highway Rated Bolted Composite Cover

6" (150 mm) MPT (stainless steel)

4" (100 mm) Plain End

Accessories

AK3: Anchor Kit

FCR2: Riser to Grade

CC2: Membrane Clamping Collar Kit

Other large tank designs available. See GGI-750 and GGI-1500 online for more details.

* Add up to 4" when adapter is elevated

BIG FOOT™

Gravity Grease Interceptors

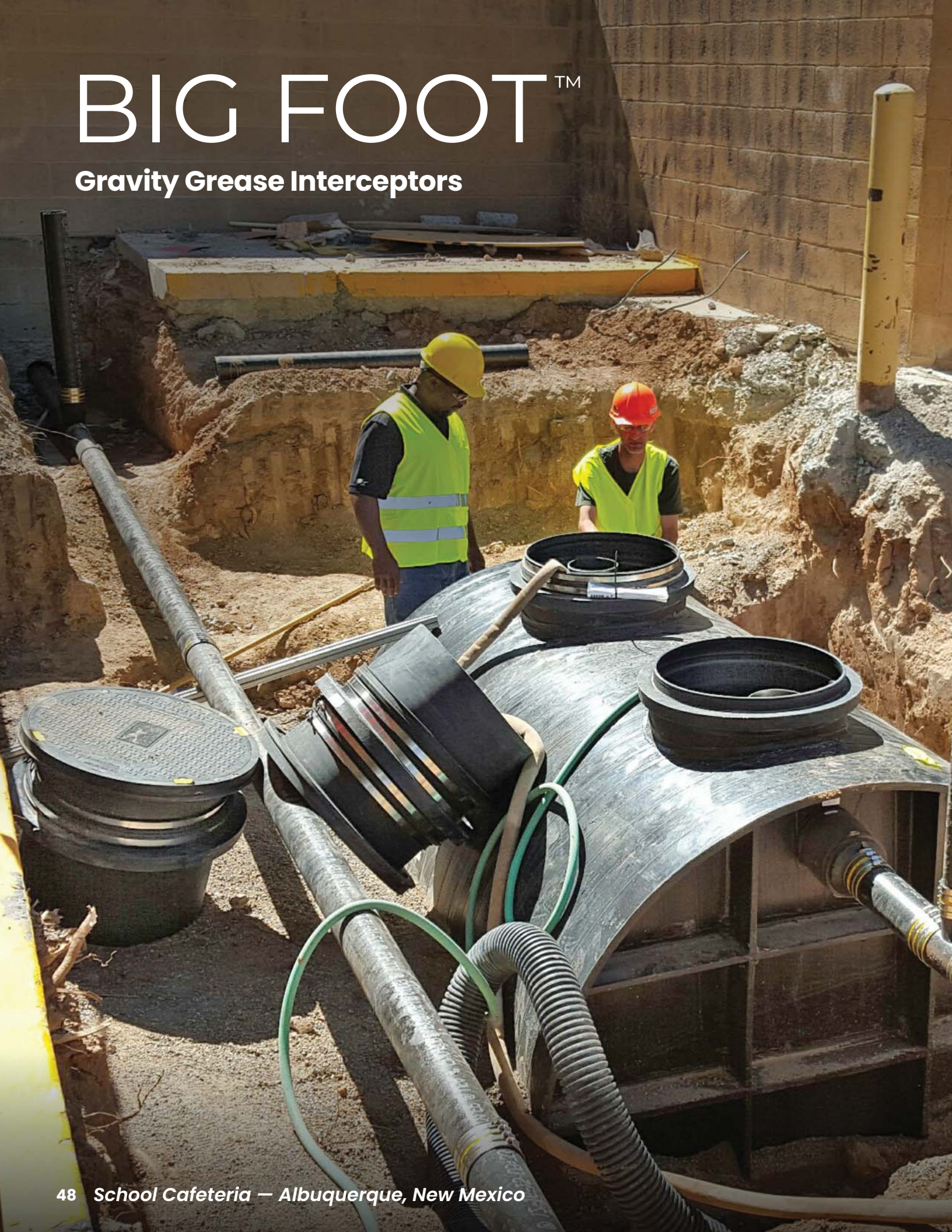



Recommended for use when gravity grease interceptors are required. Some local ordinances specifically use volume based sizing with no process for alternate approval. Big Foot™ interceptors are offered in rugged polyethylene construction for buried applications only.

GGI-750

750 Gallon Gravity Grease Interceptor



**Includes
Safety Star™**

Standard

Location: Indoor/Outdoor

Installation: Below Grade Only

Flow Rate / Grease Capacity:

100 GPM (6.3 L/s) / 5,336 lbs. (2,420 kg)

200 GPM (12.6 L/s) / 3,628 lbs. (1,646 kg)

Solids Capacity: 75 gal. (284 L)

Liquid Capacity: 815 gal. (3,085 L)

Weight: 1,316 lbs. (597 kg)

Connections: 6" (150 mm) plain end

Cover: Pickable Gas/Water Tight Cast Iron with H20 Load Rating

Listed by IAPMO to ANSI Z1001, spring 2019.

Options

C24H2: Highway Rated Bolted Composite Cover

6" (150 mm) MPT (stainless steel)

4" (150 mm) Plain End

Accessories

AK3: Anchor Kit

FCR2: Riser to Grade

CC2: Membrane Clamping Collar Kit

* Add up to 4" when adapter is elevated

GGI-1500

1500 Gallon Gravity Grease Interceptor



**Includes
Safety Star™**

Standard

Location: Indoor/Outdoor

Installation: Below Grade Only

Flow Rate / Grease Capacity:

100 GPM (6.3 L/s) / 9,818 lbs. (4,453 kg)

200 GPM (12.6 L/s) / 6,672 lbs. (3,026 kg)

Solids Capacity: 150 gal. (568 L)

Liquid Capacity: 1,500 gal. (5,678 L)

Weight: 1,816 lbs. (824 kg)

Connections: 6" (150 mm) plain end

Cover: Pickable Gas/Water Tight Cast Iron with H20 Load Rating

Listed by IAPMO to ANSI Z1001, spring 2019.

Options

C24H2: Highway Rated Bolted Composite Cover

6" (150 mm) MPT (stainless steel)

4" (150 mm) Plain End

Accessories

AK3: Anchor Kit

FCR2: Riser to Grade

CC2: Membrane Clamping Collar Kit

* Add up to 4" when adapter is elevated

SEWER VIEWER™

Sampling Ports

Take a peek under the hood.



Model GB-250 with open top outlet diffuser being used as an internal sampling port

All Great Basin™ grease interceptors include open top outlet diffusers to provide access for visual inspection. Where physical testing is required, use one of our downstream Sewer Viewer™ sampling ports.

SV24

Indoor/Outdoor Sampling Port



Standard

Location: Indoor/Outdoor

Installation: Above/Below Grade

Weight: 65 lbs. (30 kg)

Configuration: Level Connections (-L)

Connections: 4" (100 mm) plain end inlet/outlet

Accessway: 20" (500 mm)

Cover: Bolted Gas/Water Tight Composite with 16,000 lb. Load Rating

Options

Offset Connections (-O)

C24HP: H20 rated pickable cast iron cover

4" (100 mm) MPT

6" (150 mm) plain end

Accessories

SR24: short riser

LR24: long riser

ACCESSORIES

The following accessories may accompany base models at the time of purchase or separately. Covers for every application. Pumpout Ports for remote cleaning during normal business hours. Membrane clamping collars for recessed and suspended units. Fittings for jobsite piping. Anchor kits to prevent float out in exterior installation locations with high water tables*. Support kits for above grade GB-500 installations or indoor unit flush-to-grade burials. See compatibility chart to identify which accessories are available with according base models.

Anchor Kit

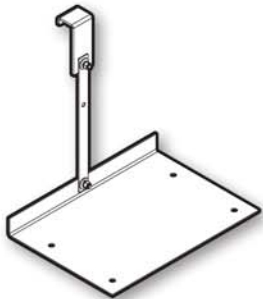

AK1



AK2 / AK3

Covers



C21M



C24H



C24H2



C24HP

Risers



FCR1

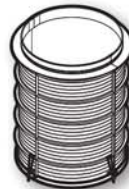

FCR2



SR24



LR24

Pumpout Ports



PP1



PP2

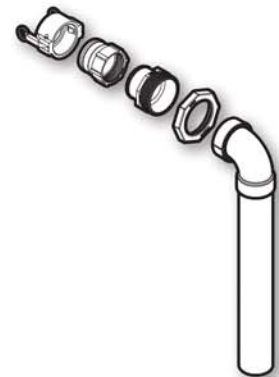

PP3

* These areas include, but are not limited to, tidal surge areas, floodplains and areas that receive storm water.

Support Kits



AGS2
(for GB-500 only)

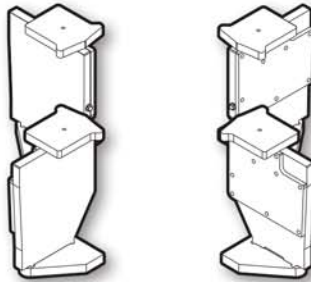

SGK2 / SGK3
(for GB2 and GB3 only)

Fittings



PLAIN-EA-24



PLAIN-EA-34



PLAIN-EA-44



FPT-EA-23



FPT-EA-34

Membrane Clamping Collars



CC1



CC2

COMPATIBILITY		GB1	GB2	GB3	GB-50, GB-75, GB-250	GB-500	GB-1000	GGI-750, GGI-1500	SV24
Anchor Kits	AK1				●				
	AK2					●			
	AK3						●	●	
Covers	C21M	○	○	○					
	C24H				○				○
	C24H2					●	●	●	
	C24HP				●	○	○	○	●
Risers	FCR1	●	●	●					
	FCR2					●	●	●	
	SR24				●				●
	LR24				●				●
Pumpout Port Kits	PP1	●	●	●					
	PP2				●				
	PP3					●			
Clamping Collars	CC1	●	●	●					
	CC2				●	●	●	●	
Fittings*	PLAIN-EA-24	○	●	●		●			
	PLAIN-EA-34	○	○	●		●			
	PLAIN-EA-44	●	○	○		○			
	FPT-EA-23	●	●	●		●			
	FPT-EA-34	●	●	●		●			
Support Kits	AGS2					●			
	SGK2		●						
	SGK3			●					

● Additional ○ Standard *Available in Boxes of 12



9500 Woodend Road | Edwardsville, KS 66111

LIFETIME GUARANTEED GREASE INTERCEPTORS

schierproducts.com 

Visit our website for technical data, official product certifications and testing reports, pricing and more.

inquiry@schierproducts.com
tel: 1-913-951-3300

C-0419-ENG

© Copyright 2019 Schier. All Rights Reserved