

STRIEM



BUILT IN KANSAS CITY

MANUFACTURERS OF:

OIL SEPARATORS

SOLIDS INTERCEPTORS

CHEMICAL WASTE TANKS



**PRODUCT
CATALOG**
2 0 1 9

THANK YOU FOR TRUSTING US

At Striem, we make three things: oil separators, solids interceptors, and chemical waste tanks. If we don't make them right, we have nothing to fall back on. This tends to keep us very sharp.

Whether you're specifying, buying, installing, or maintaining one of our products, we thank you for trusting us.

We want to make a promise. If you call us, we will provide best-in-class customer service. If you interact with our product, it will be easy.

If you think we didn't hold up our end of the bargain, call us and we'll make it right.



VINCE ISMERT
Direct: 816-591-9765

A handwritten signature in black ink that reads "Vince Ismert".

GABE ISMERT
Direct: 816-820-5454

A handwritten signature in black ink that reads "Gabe Ismert".

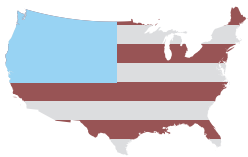

100% American Made

If you want to speak to the fabricator who built your product, call us. If you want to meet him or her, drop by our factory. All of our products are 100% American made, now and forever.



Lifetime Guarantee

Our polyethylene products are designed to last the lifetime of the plumbing system in which they are installed. If they don't, we will repair or replace them at no charge. Product damage due to normal wear and tear may be repaired or replaced at a reasonable charge.

TABLE OF CONTENTS

OIL SEPARATORS

Flow Rate Based	3
Volume Based	5
Slick Stick™ Oil Level Monitoring System	7

SOLIDS INTERCEPTORS

Aardvark™ basket style solids interceptors	9
HLT/B and USI Series under counter solids interceptors	11
Prospector™ screen style solids interceptors	12
Settler™ catch basins	13

CHEMICAL WASTE TANKS

Lab Rat™ under counter neutralization tanks	15
Lab Basin™ centralized neutralization tanks	16
Command Center™ pH monitoring package	17
Bio Basin™ decontamination tanks	18

ACCESSORIES

Covers	19
Risers	19
High water anchor kits	20

APPENDIX

Terms and Conditions.	21
-------------------------------	----

TALK TO A HUMAN

8:00 a.m. – 5:00 p.m. CST (Monday through Friday)
Tel: 913-222-1500
email: help@striemco.com | orders@striemco.com

FLOW RATE BASED OIL SEPARATORS



ONLINE SIZING TOOL
 SIZE AN OIL SEPARATOR IN 30 SECONDS

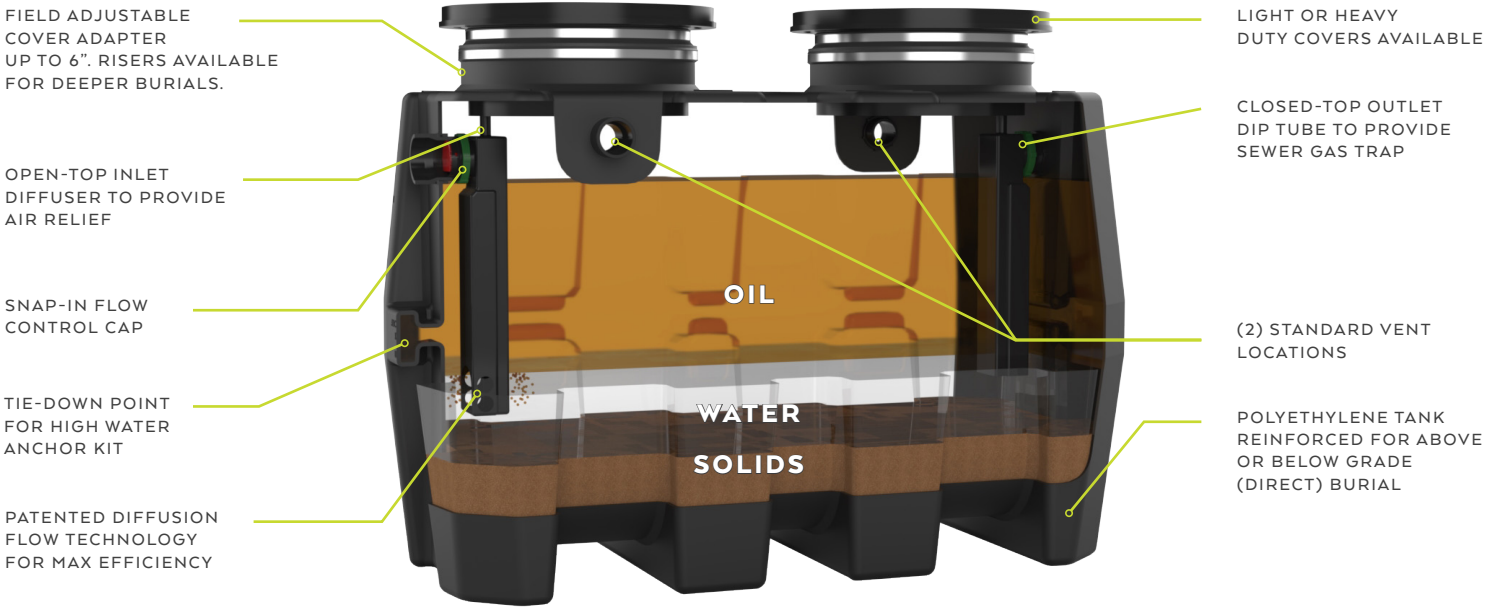

PICTURED: OS-100

APPLICATIONS

**AUTO SERVICE/
REPAIR STATIONS**



**FIRE HOUSE/
POLICE STATIONS**



**PARKING
GARAGES**

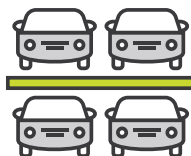

**HYDRAULIC
ELEVATOR PITS**

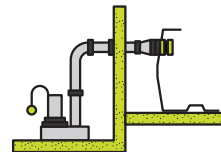

**LOADING
DOCKS**



Formats available online



OS-15

CONNECTIONS: 2"
MAX FLOW RATE: 15 GPM
LIQUID CAPACITY: 16 GAL.
OIL CAPACITY: 10 GAL.
SAND CAPACITY: 1 GAL.
WEIGHT: 28 LBS.



OS-25

CONNECTIONS: 3"
MAX FLOW RATE: 25 GPM
LIQUID CAPACITY: 21 GAL.
OIL CAPACITY: 15 GAL.
SAND CAPACITY: 6 GAL.
WEIGHT: 31 LBS.

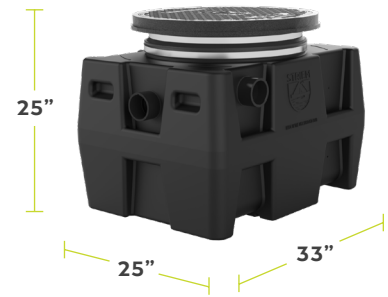

OS-35

CONNECTIONS: 3"
MAX FLOW RATE: 35 GPM
LIQUID CAPACITY: 38 GAL.
OIL CAPACITY: 28 GAL.
SAND CAPACITY: 6 GAL.
WEIGHT: 77 LBS.



OS-50

CONNECTIONS: 4"
MAX FLOW RATE: 50 GPM
LIQUID CAPACITY: 57 GAL.
OIL CAPACITY: 40 GAL.
SAND CAPACITY: 7 GAL.
WEIGHT: 92 LBS.



OS-75

CONNECTIONS: 4", 6" OPTIONAL
MAX FLOW RATE: 75 GPM
LIQUID CAPACITY: 110 GAL.
OIL CAPACITY: 93 GAL.
SAND CAPACITY: 11 GAL.
WEIGHT: 130 LBS.



OS-100

CONNECTIONS: 4", 6" OPTIONAL
MAX FLOW RATE: 100 GPM
LIQUID CAPACITY: 250 GAL.
OIL CAPACITY: 144 GAL.
SAND CAPACITY: 95 GAL.
WEIGHT: 230 LBS.

VOLUME BASED OIL SEPARATORS



ONLINE SIZING TOOL
 SIZE AN OIL SEPARATOR IN 30 SECONDS

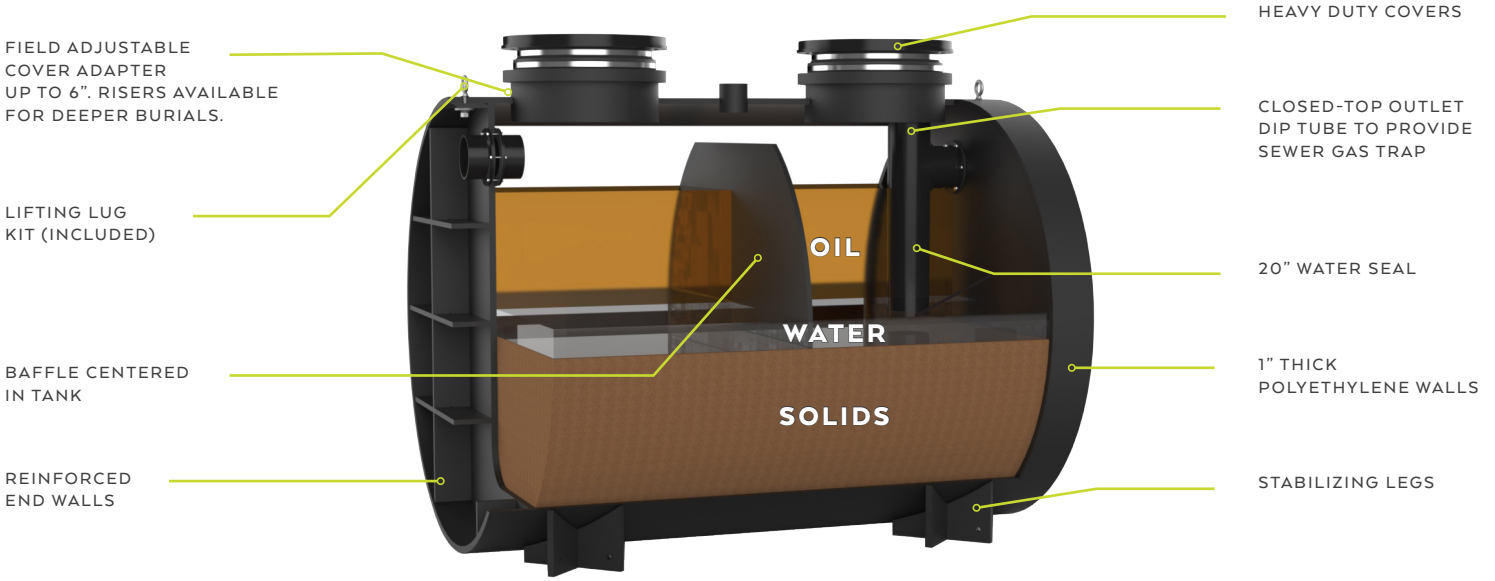

PICTURED: OS-1000

APPLICATIONS

**AUTO SERVICE/
REPAIR STATIONS**



**FIRE HOUSE/
POLICE STATIONS**



**PARKING
GARAGES**

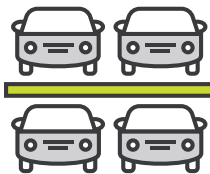

**LOADING
DOCKS**

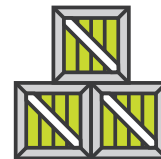

HANGARS



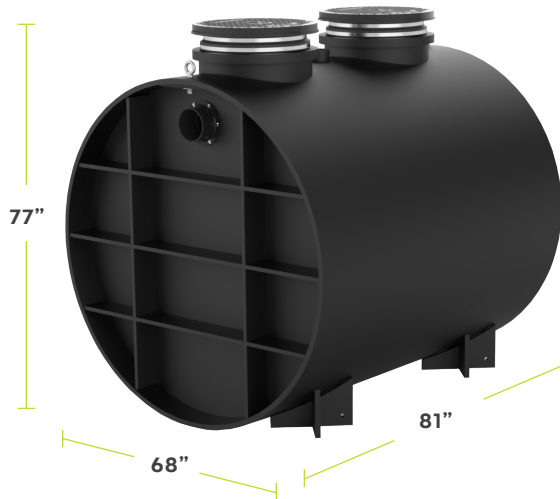

OS-750

CONNECTIONS: 6", 4" OPTIONAL
MAX FLOW RATE: 314 GPM
LIQUID CAPACITY: 750 GAL.
OIL CAPACITY: 401 GAL.
SAND CAPACITY: 307 GAL.
WEIGHT: 1,200 LBS.



OS-1000

CONNECTIONS: 6", 4" OPTIONAL
MAX FLOW RATE: 314 GPM
LIQUID CAPACITY: 1,000 GAL.
OIL CAPACITY: 451 GAL.
SAND CAPACITY: 347 GAL.
WEIGHT: 1,400 LBS.



OS-1500

CONNECTIONS: 6", 4" OPTIONAL
MAX FLOW RATE: 314 GPM
LIQUID CAPACITY: 1,500 GAL.
OIL CAPACITY: 610 GAL.
SAND CAPACITY: 486 GAL.
WEIGHT: 1,700 LBS.

SLICK STICK™

OIL LEVEL MONITORING SYSTEM

TAKE THE GUESSWORK OUT OF OIL LEVEL MONITORING

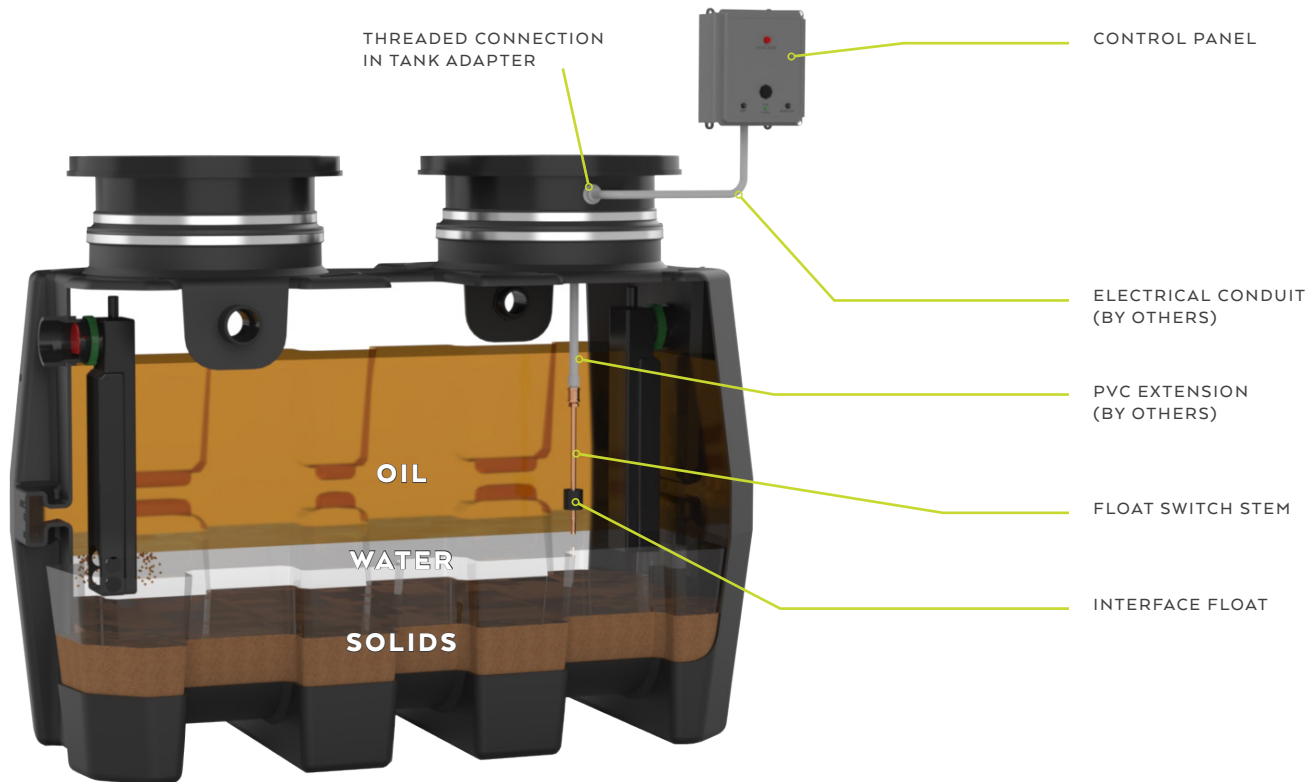

PICTURED: OS-100-SS

AVAILABLE MODELS

- OS-50-SS
- OS-75-SS
- OS-100-SS
- OS-750-SS
- OS-1000-SS
- OS-1500-SS

FEATURES

- UL listed
- Intrinsically safe
- Field-extendable interface float
- Ability to easily install with risers
- Audio and visual alarm
- BMS capability

INSTALLATION WITH RISERS

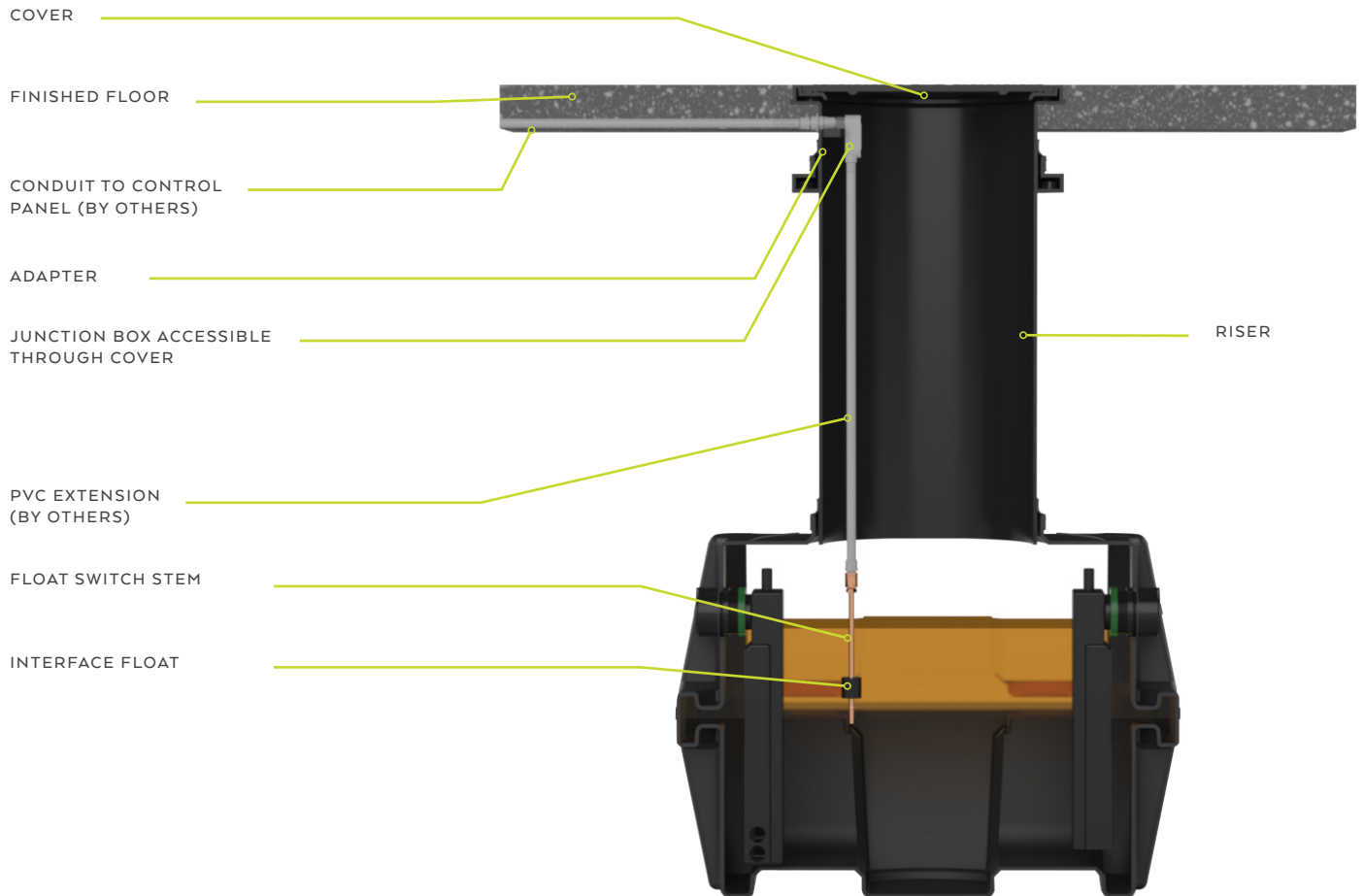

PICTURED: OS-75-SS

SPECIFICATIONS

- Provides audio/visual alarm under high oil level condition.
- Single phase, 120 VAC, 60 hertz input power required.
- NEMA 4X enclosure.
- “HORN OFF” button silences audible alarm.
- “TEST” button tests system electronics.
- Locking clasp on door.
- Intrinsically safe sensor inputs.
- Interface float is buoyant in water, but sinks in the presence of hydrocarbons.

AARDVARK™ SERIES

BASKET-STYLE SOLIDS INTERCEPTORS

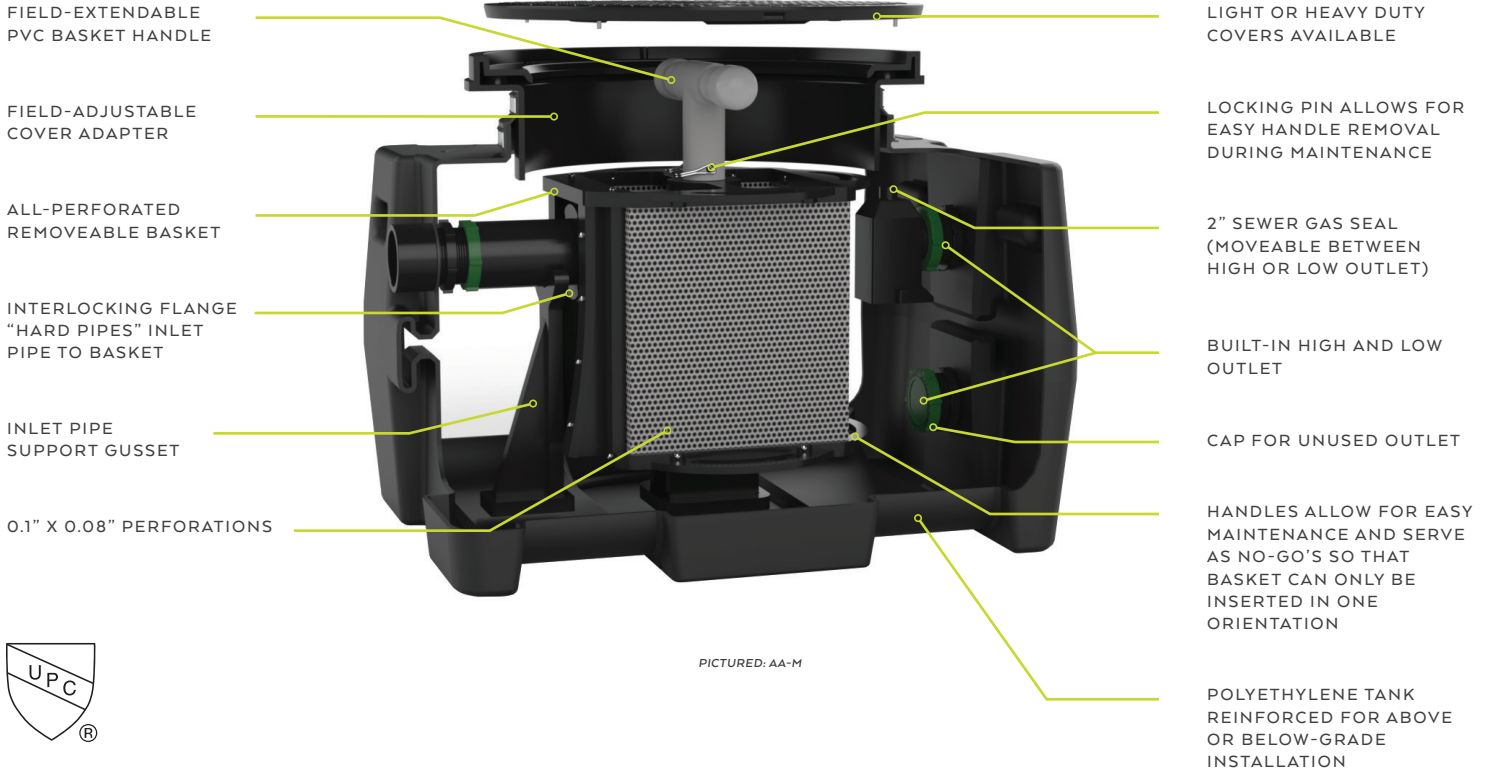

APPLICATIONS

LAUNDRY FACILITIES



COMMERCIAL KITCHENS

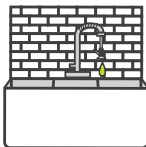

DOG WASH & PET KENNELS



ART ROOM SINKS



BARBER SHOPS & HAIR SALONS



FOOD PROCESSING



Formats available online



AA-S
SMALL

CONNECTIONS: 2"
MAX FLOW RATE: 35 GPM
LIQUID CAPACITY: 16 GAL. (HIGH OUTLET),
 4 GAL. (LOW OUTLET)
SOLIDS CAPACITY: 2 GAL.
WEIGHT: 42 LBS.

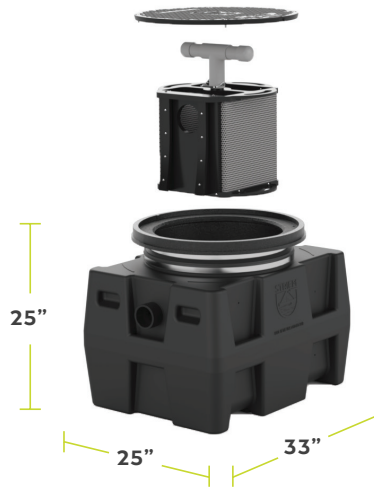

AA-M
MEDIUM

CONNECTIONS: 3"
MAX FLOW RATE: 50 GPM
LIQUID CAPACITY: 38 GAL. (HIGH OUTLET),
 12 GAL. (LOW OUTLET)
SOLIDS CAPACITY: 6 GAL.
WEIGHT: 83 LBS.

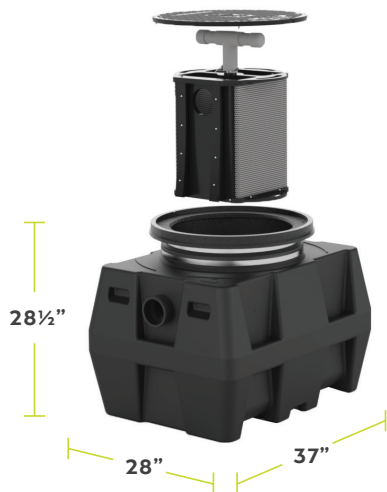

AA-L
LARGE

CONNECTIONS: 4"
MAX FLOW RATE: 75 GPM
LIQUID CAPACITY: 57 GAL. (HIGH OUTLET),
 14 GAL. (LOW OUTLET)
SOLIDS CAPACITY: 8 GAL.
WEIGHT: 105 LBS.



AA-XL
EXTRA LARGE

CONNECTIONS: 4", 6" OPTIONAL
MAX FLOW RATE: 100 GPM
LIQUID CAPACITY: 110 GAL. (HIGH OUTLET),
 30 GAL. (LOW OUTLET)
SOLIDS CAPACITY: 10 GAL.
WEIGHT: 145 LBS.

SPECIFICATIONS & SUBMITTALS

Formats available online



HLT/B SERIES

UNDER COUNTER HAIR INTERCEPTOR

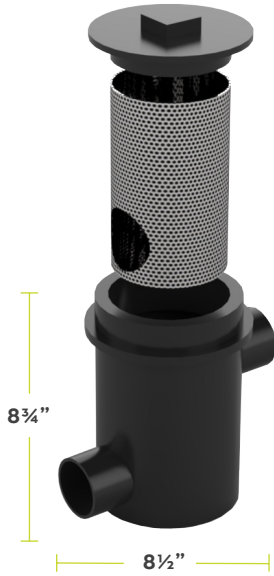

TOP ACCESS



BOTTOM ACCESS

MODEL NUMBER	ACCESS LOCATION	CONNECTION SIZE
HLT-1176-1	TOP	1"
HLT-1176-2	TOP	2"
HLB-1176-1	BOTTOM	1"
HLB-1176-2	BOTTOM	2"

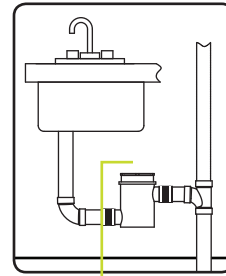

7" MIN.

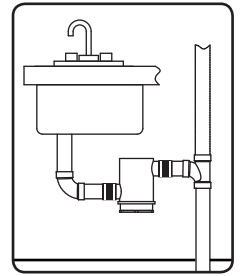

USI SERIES

UNDER COUNTER CLAY & PLASTER TRAP



TOP ACCESS



BOTTOM ACCESS

MODEL NUMBER	ACCESS LOCATION	CONNECTION SIZE
USI-1180-1	TOP	1"
USI-1180-2	TOP	2"
USI-1184-1	BOTTOM	1"
USI-1184-2	BOTTOM	2"

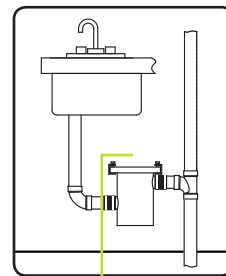

9" MIN.

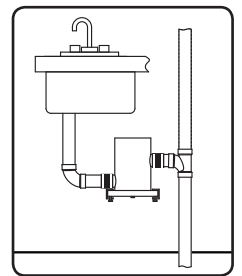

PROSPECTOR™ SERIES

SCREEN-STYLE SOLIDS INTERCEPTORS

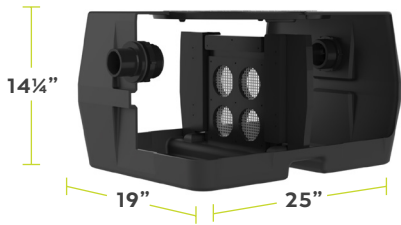

PS-15-S

CONNECTIONS: 2"
MAX FLOW RATE: 19 GPM
LIQUID CAPACITY: 16 GAL.
SOLIDS CAPACITY: 8 GAL.
WEIGHT: 29 LBS.

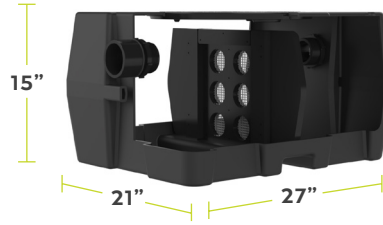

PS-25-S

CONNECTIONS: 3"
MAX FLOW RATE: 59 GPM
LIQUID CAPACITY: 21 GAL.
SOLIDS CAPACITY: 11 GAL.
WEIGHT: 35 LBS.

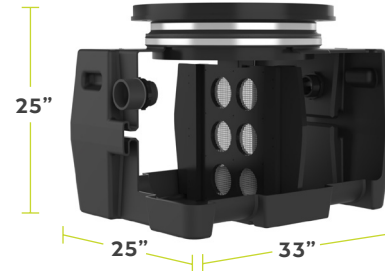

PS-35-S

CONNECTIONS: 3"
MAX FLOW RATE: 59 GPM
LIQUID CAPACITY: 38 GAL.
SOLIDS CAPACITY: 17.5 GAL.
WEIGHT: 83 LBS.



PS-50-S

CONNECTIONS: 4"
MAX FLOW RATE: 126 GPM
LIQUID CAPACITY: 57 GAL.
SOLIDS CAPACITY: 26 GAL.
WEIGHT: 106 LBS.

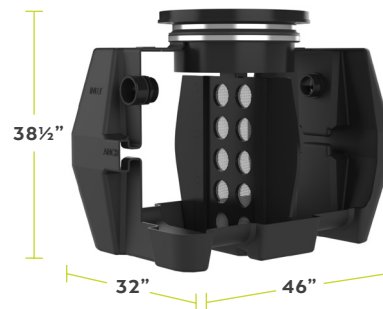

PS-125-S

CONNECTIONS: 4", 6" OPTIONAL
MAX FLOW RATE: 126 GPM
LIQUID CAPACITY: 110 GAL.
SOLIDS CAPACITY: 62.5 GAL.
WEIGHT: 140 LBS.

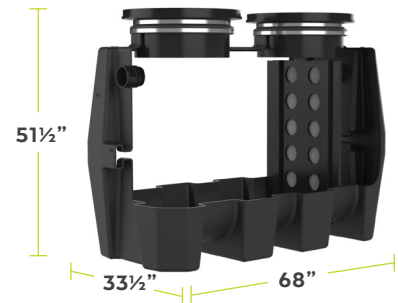

PS-275-S

CONNECTIONS: 4", 6" OPTIONAL
MAX FLOW RATE: 126 GPM
LIQUID CAPACITY: 250 GAL.
SOLIDS CAPACITY: 210 GAL.
WEIGHT: 270 LBS.

SETTLER™ SERIES

CATCH BASINS

CB-50-S

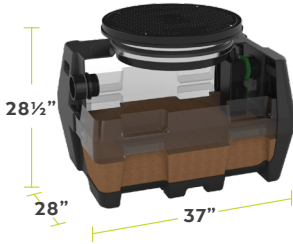

CONNECTIONS: 4"
MAX FLOW RATE: 126 GPM
LIQUID CAPACITY: 57 GAL.
SOLIDS CAPACITY: 25 GAL.
WEIGHT: 86 LBS.

CB-50-G

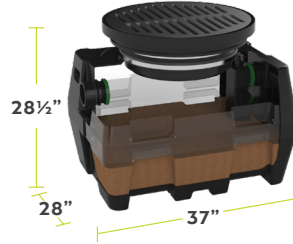

CONNECTIONS: 4"
MAX FLOW RATE: 126 GPM
LIQUID CAPACITY: 57 GAL.
SOLIDS CAPACITY: 25 GAL.
WEIGHT: 187 LBS.

CB-125-S

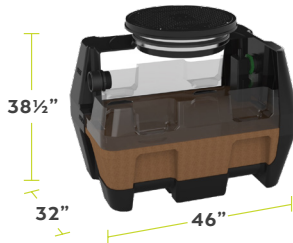

CONNECTIONS: 4"
MAX FLOW RATE: 126 GPM
LIQUID CAPACITY: 110 GAL.
SOLIDS CAPACITY: 70 GAL.
WEIGHT: 130 LBS.

CB-125-G

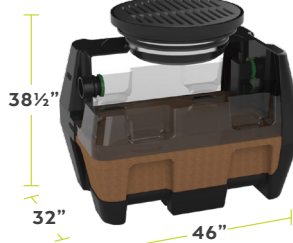

CONNECTIONS: 4", 6" OPTIONAL
MAX FLOW RATE: 126 GPM
LIQUID CAPACITY: 110 GAL.
SOLIDS CAPACITY: 70 GAL.
WEIGHT: 213 LBS.

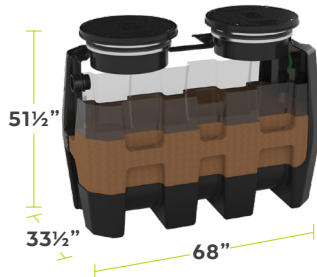

CB-275-S

CONNECTIONS: 4", 6" OPTIONAL
MAX FLOW RATE: 126 GPM
LIQUID CAPACITY: 250 GAL.
SOLIDS CAPACITY: 200 GAL.
WEIGHT: 218 LBS.

COVERS

BOLTED COMPOSITE



16,000 LBS. HIGHWAY LOAD RATING

PICKABLE CAST IRON



16,000 LBS. H2O LOAD RATING

PICKABLE GRATE

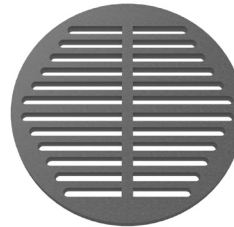

16,000 LBS. H2O LOAD RATING

BCB-7



OPTIONAL 7-GAL SEDIMENT BASKET (G MODELS ONLY)

**THIS PAGE
(UN)INTENTIONALLY
LEFT BLANK,
SO HERE
ARE SOME
JUMBLES*.**

**ISMERT
SAMEK
MEFILITE
REEDAGUANT
ORDSTCUP**

Formats available online



LAB RAT™ SERIES

UNDER COUNTER NEUTRALIZATION

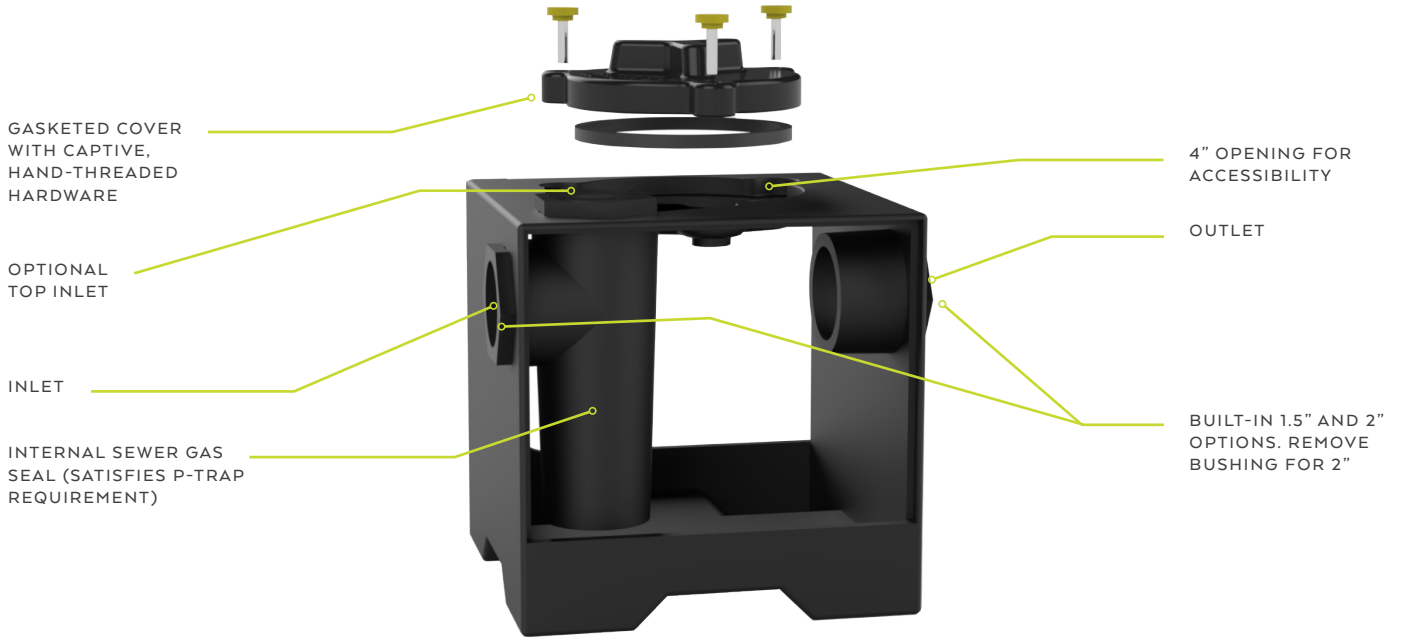

PICTURED: LB-2

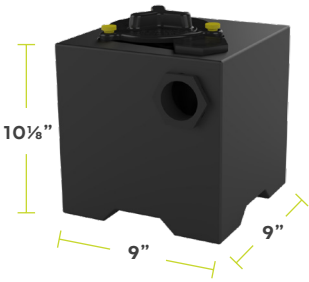

LB-2

CONNECTIONS: 1.5" AND 2"
LIQUID CAPACITY: 2 GAL.
OF LAB SINKS: 1
LIMESTONE LOAD: 25 LBS.
WEIGHT: 6 LBS.

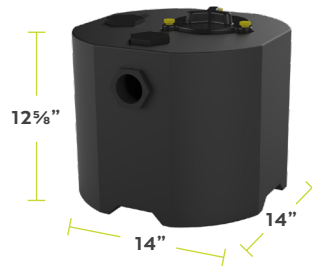

LB-5

CONNECTIONS: 1.5" AND 2"
LIQUID CAPACITY: 5 GAL.
OF LAB SINKS: 2
LIMESTONE LOAD: 50 LBS.
WEIGHT: 11 LBS.

APPLICATION LAYOUTS

LB-2

4" PVC PIPE CUT TO SIZE (BY OTHERS)

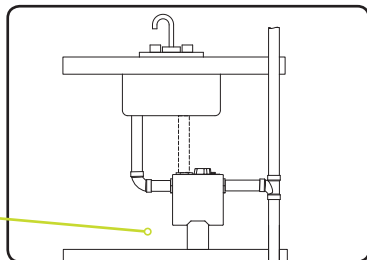

LAB SINK

LB-5

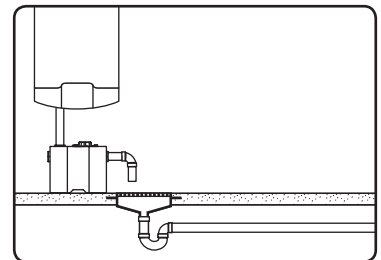

WATER HEATER CONDENSATE LINE

LAB BASIN™

CENTRALIZED NEUTRALIZATION

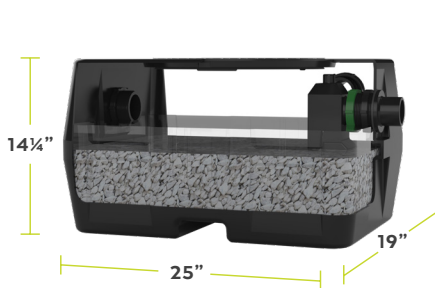

LB-15

CONNECTIONS: 2"
LIQUID CAPACITY: 16 GAL.
OF LAB SINKS: 4
LIMESTONE LOAD: 200 LBS.
WEIGHT: 28 LBS.

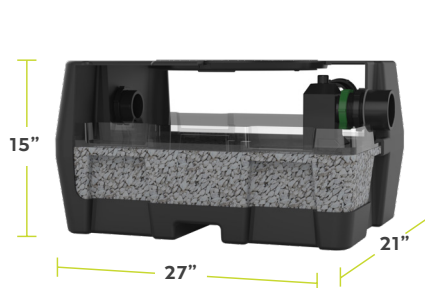

LB-25

CONNECTIONS: 2", 3"
LIQUID CAPACITY: 21 GAL.
OF LAB SINKS: 6
LIMESTONE LOAD: 300 LBS.
WEIGHT: 31 LBS.

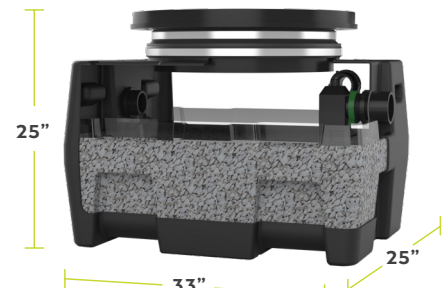

LB-35

CONNECTIONS: 2", 3", 4"
LIQUID CAPACITY: 38 GAL.
OF LAB SINKS: 9
LIMESTONE LOAD: 450 LBS.
WEIGHT: 77 LBS.

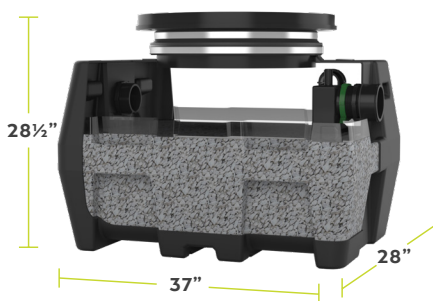

LB-50

CONNECTIONS: 2", 3", 4"
LIQUID CAPACITY: 57 GAL.
OF LAB SINKS: 15
LIMESTONE LOAD: 650 LBS.
WEIGHT: 92 LBS.

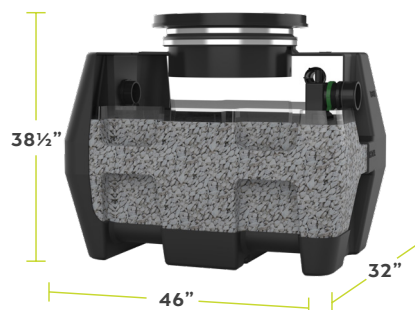

LB-125

CONNECTIONS: 2", 3", 4", 6"
LIQUID CAPACITY: 110 GAL.
OF LAB SINKS: 35
LIMESTONE LOAD: 1,550 LBS.
WEIGHT: 130 LBS.

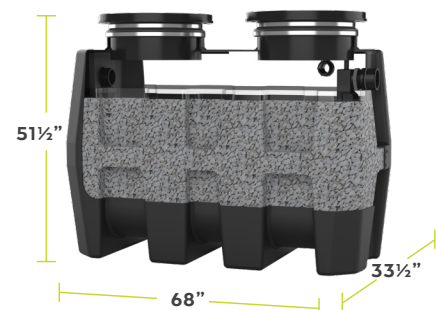

LB-275

CONNECTIONS: 2", 3", 4", 6"
LIQUID CAPACITY: 250 GAL.
OF LAB SINKS: 75
LIMESTONE LOAD: 3,150 LBS.
WEIGHT: 230 LBS.

COMMAND CENTER™

PH MONITORING PACKAGE

- BMS CAPABILITY VIA ETHERNET CONNECTION
- PRE-PROGRAMMED AUDIO/VISUAL ALARM SET POINTS
- 3.5" COLOR TOUCHSCREEN DISPLAY
- STORAGE: INCLUDES (2), 1-YEAR MICRO SD CARDS
- PRE-PROGRAMMED W/DIGITAL OUTPUT TO POWER SOLENOID VALVE FOR FRESH WATER TO FLUSH IF PH APPROACHES HIGH/LOW LIMITS
- NEMA 4X LOCKABLE WEATHER PROOF ENCLOSURE - 32°F TO 122°F
- 120V AC POWER SUPPLY REQUIRED



CLEAR FRONT PANEL



TOUCHSCREEN INTERFACE

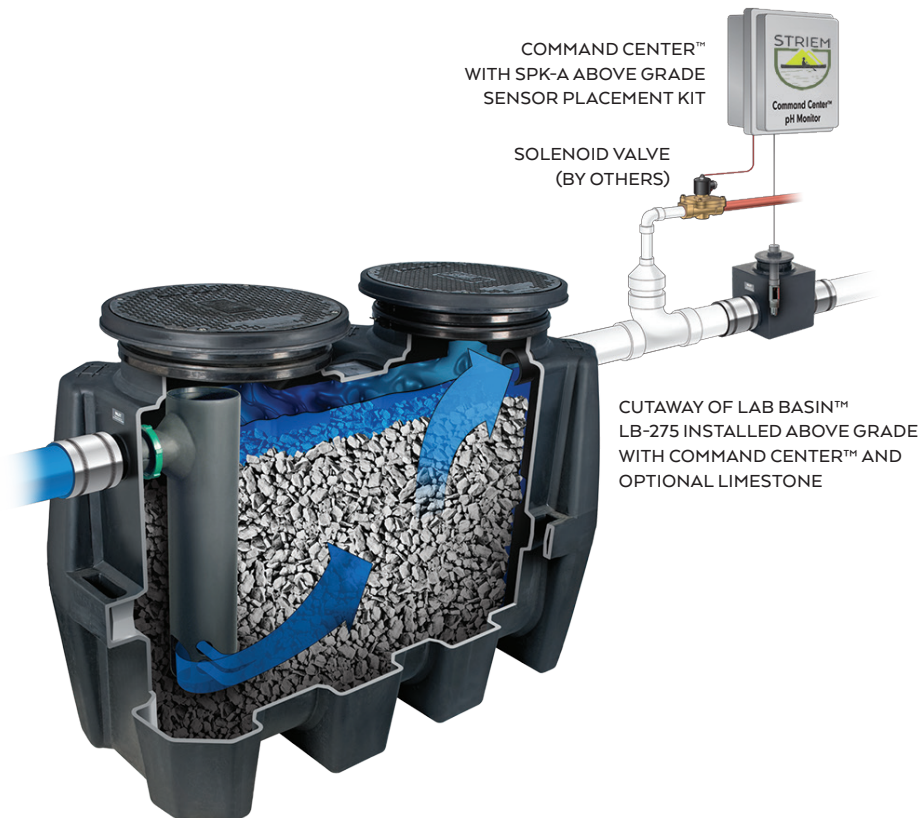

Formats available online



BIO BASIN™ SERIES

DECONTAMINATION TANKS



BB-275

CONNECTIONS: 4", 6"
LIQUID CAPACITY: 250 GAL.
WEIGHT: 230 LBS.

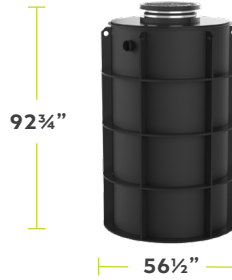

BB-500

CONNECTIONS: 4", 6"
LIQUID CAPACITY: 584 GAL.
WEIGHT: 435 LBS.

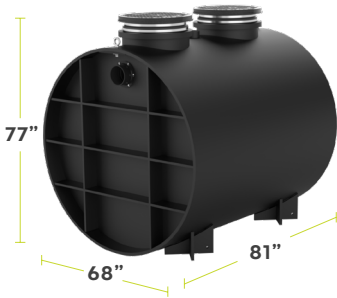

BB-750

CONNECTIONS: 4", 6"
LIQUID CAPACITY: 750 GAL.
WEIGHT: 1,200 LBS.

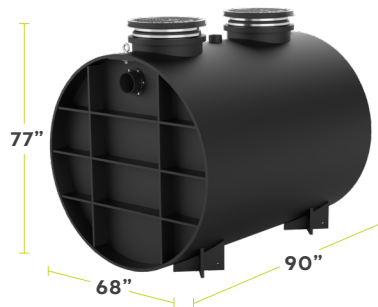

BB-1000

CONNECTIONS: 4", 6"
LIQUID CAPACITY: 1,000 GAL.
WEIGHT: 1,400 LBS.

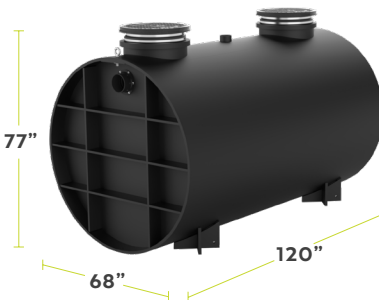

BB-1500

CONNECTIONS: 4", 6"
LIQUID CAPACITY: 1,500 GAL.
WEIGHT: 1,700 LBS.

MONITORING PACKAGES

AVA-3
 SINGLE LEVEL
 MONITORING PACKAGE

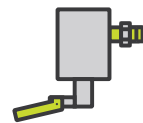

AVA-4
 MULTI-LEVEL
 MONITORING PACKAGE



STRIEM RECOMMENDS THE FOLLOWING STEPS FOR SIZING A DECONTAMINATION TANK:

$$\left[\begin{array}{l} \text{Number of} \\ \text{Fixtures (showers} \\ \text{or eyewash} \\ \text{stations)} \end{array} \right] \times \left[\begin{array}{l} \text{Supply Line} \\ \text{Flow Rate of} \\ \text{Each Fixture} \\ \text{(see table right)} \end{array} \right] \times \left[\begin{array}{l} \text{Rinse Time} \\ \text{(15-20} \\ \text{minutes} \\ \text{typical)} \end{array} \right] = \text{SIZE OF TANK IN GALLONS}$$

SIZING SAMPLE:

1. A hospital with two emergency showers, each with a 3/4" supply line carrying a flow rate of 9.96 GPM. 2 fixtures x 9.96 GPM = 19.92 GPM
2. 19.92 GPM x 15 minutes = 298.8 gallons
3. Select Bio Basin™ model BB-500 (500 liquid holding gallons)

SUPPLY LINE FLOW RATES

VELOCITY	1/2"	3/4"
4 FT./SEC	3.77 GPM	6.64 GPM
6 FT./SEC	5.66 GPM	9.96 GPM
8 FT./SEC	7.54 GPM	13.29 GPM
10 FT./SEC	9.43 GPM	16.61 GPM

COVERS



C16M

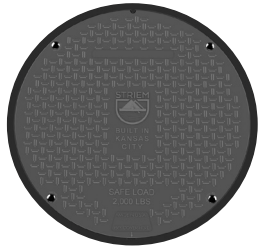

C24M

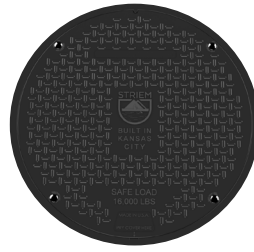

C24H

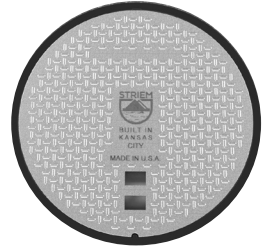

C24HP

LOCATION:

INDOOR

INDOOR

INDOOR/OUTDOOR

INDOOR/OUTDOOR

DIAMETER:

16"

24"

24"

24"

TYPE:

BOLTED POLYPRO

BOLTED COMPOSITE

BOLTED COMPOSITE

PICKABLE CAST IRON

LOAD RATING:

2,000 LBS.

2,000 LBS.

16,000 LBS.

16,000 LBS. H2O RATED

FIELD-ADJUSTABLE RISERS

SEE PRODUCT SPECIFICATIONS FOR RISER OPTIONS

SR-16



SR-24



LR-24



**TILT ADAPTER UP TO 10°
IN ALL DIRECTIONS**



HIGH WATER ANCHOR KITS

AK-1

- STAINLESS STEEL ANCHOR KIT
- COMPATIBLE WITH: 50, 110 AND 250 GALLON TANKS



HDK-1

- NYLON STRAP ANCHOR KIT
- COMPATIBLE WITH: 750, 1,000 AND 1,500 GALLON TANKS



APPENDIX

TERMS AND CONDITIONS

All Customers: The following terms and conditions pertain to qualified customers only. Striem, at its option, may qualify or disqualify any customer. All prices are subject to change without notice.

International Customers: All border crossing fees are paid by the importing customer. Contact Striem for further information on NAFTA and HTS numbers.

Credit Terms: 2% 10 days, net 30.

A 2% discount may be taken if payment is received on or before the 10th day from date of invoice. Full payment is required on or before the 30th day from date of invoice. A 2% service charge will be applied to all overdue accounts. Accounts that regularly pay beyond net terms will be denied open account status. All prices are subject to change without notice. Invoices may be sent via email upon request.

Freight Terms: Shipments are F.O.B. Kansas City, KS. Freight charges are pre-paid and billed with product invoice.

Returned Goods: Effective March 2nd, 2015, standard catalog products may be returned with a Striem-issued RGA if they are in saleable condition within 6 months of the purchase date. A 5% restock fee of the original invoiced amount will apply. The customer is responsible for returned freight. If the product is damaged or incomplete, additional charges may apply. Made-to-order products are non-returnable.

ANSWERS: STRIEM, MAKES, LIFETIME, GUARANTEED, PRODUCTS

NOTES





PH 913-222-1500
STRIEMCO.COM

help@striemco.com
orders@striemco.com

